

ARO[®]

Automatic Machining tools

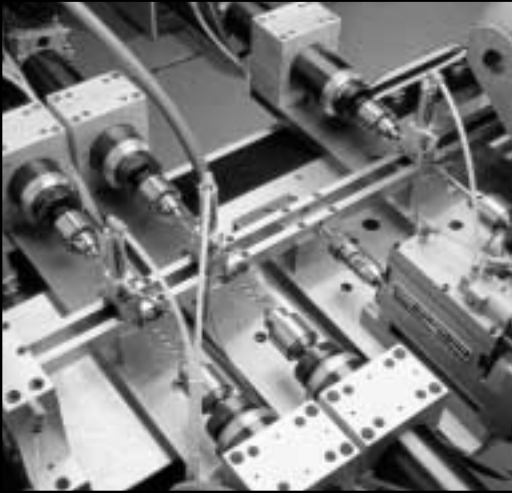

ARO[®]

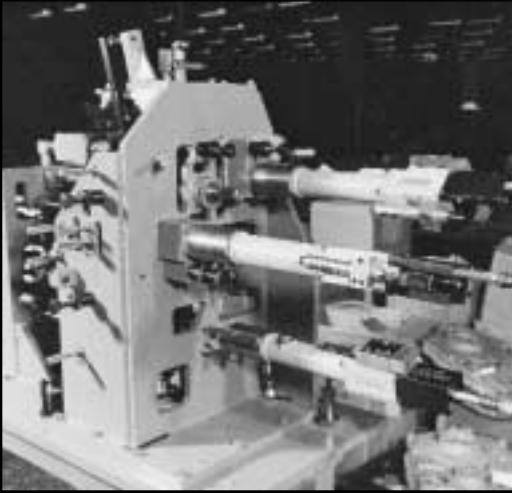

ARO[®]

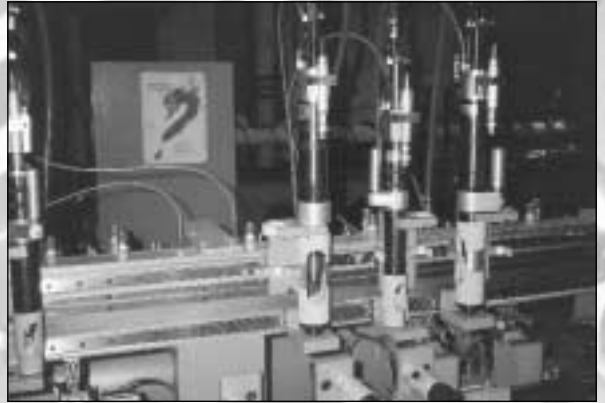
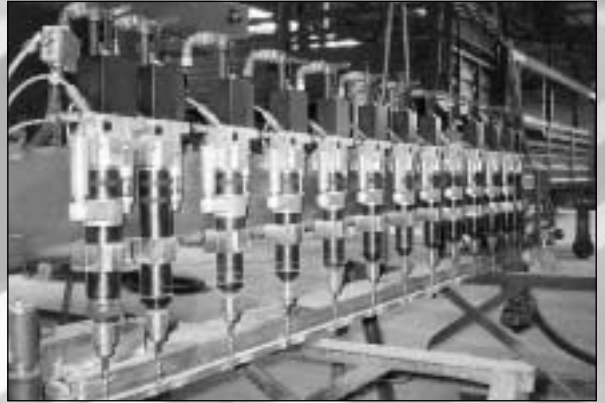

Automatic Machining Tools

Table of Contents

General introduction to the range; Machining tools and accessories	4
Pneumatic self feed units: BANT-A-MATIC series	
• Drilling version	6
• Adjustable twin head spindle version	7
• Tapping version	8
• Spindle accessories	9
• Mounting accessories	10
• Tubular mounting system	24
• Control accessories	25
Pneumatic self feed units: PAR-A-MATIC series	
• Drilling version	12
• Peck feed drill	13
• Adjustable twin head spindle version	14
• Tapping version	15
• Spindle accessories	16
• Mounting accessories	17
• Tubular mounting system	24
• Control accessories	25
Pneumatic self feed units: SUPER PAR-A-MATIC series	
• Drilling version	19
• Adjustable twin head spindle version	20
• Spindle accessories	21
• Mounting accessories	22
• Tubular mounting system	24
• Control accessories	25
Pneumatic self feed units: HI-THRUST 8660 and 8670 series	
• Specifications	26
• Spindle accessories	27
• Mounting accessories	28
Electro-pneumatic self feed units: FE054C and FE074A series	
• Specifications	30
• Service kits	30
• Spindle accessories	32
• Mounting accessories	33
Cutting speed and lubrication instructions - Helical drill bits	34

BANT-A-MATIC

PAR-A-MATIC

SUPER PAR-A-MATIC

HI-THRUST 8660 - 8670

FE054C & FE074A

General Introduction to the Range

Main Features

Motor Power (kW)	Thrust at 6.2 bar (kg)	Nominal Capacity (mild steel) (mm)	Max. Stroke (mm)	Air Consumption (l/sec.)	Available Free Speeds (rpm)						
------------------	------------------------	------------------------------------	------------------	--------------------------	-----------------------------	--	--	--	--	--	--

PNEUMATIC PRODUCTION DRILLS

BANT-A-MATIC DRILLS - 8245 SERIES (valve in head models) and 8345 SERIES (thru-head models)												
0.185	41	4.8	76	7	19000	10000	4400	2700	900			
PAR-A-MATIC DRILLS - 8255 SERIES (valve in head models) and 8355 SERIES (thru-head models)												
0.370	77	7.9	76	11	17000	10000	5000	2800	2100	1450	850	500
SUPER PAR-A-MATIC DRILLS - 8265 SERIES (valve in head models)												
0.625	114	12.7	76	14	17000	10000	4600	2500	1200	650	350	
PAR-A-MATIC PECK FEED RILLS - 8360 SERIES (valve in head models)												
0.370	77	7.9	76	11	17000	5000	2800	2100	1450	850	500	
HI-THRUST DRILLS - 8660 SERIES (valve in head models)												
0.560	160	13	76	15	16000	11500	4500	2700	1300	750	450	
HI-THRUST DRILLS - 8670 SERIES (valve in head models)												
0.930	227	16	76	23	4700	2800	1350	800	450			

ADJUSTABLE TWIN HEAD PNEUMATIC PRODUCTION DRILLS

BANT-A-MATIC TWIN HEAD DRILLS - 8248 SERIES (valve in head models)												
0.185	41	3.2	76	7	4400	2700	900					
PAR-A-MATIC TWIN HEAD DRILLS - 8258 SERIES (valve in head models)												
0.370	77	6.4	76	11	5000	2800	2100	1450	850	500		
SUPER PAR-A-MATIC TWIN HEAD DRILLS - 8268 SERIES (valve in head models)												
0.625	114	9.5	76	14	4600	2500	1200	650	350			

ELECTRO-PNEUMATIC PRODUCTION DRILLS

FE054C and FE074A SERIES DRILLS												
From 0,37 to 0,56	From 41 to 114	Up to 9,5	110	From 7 to 14	From 600 to 6400							

PNEUMATIC PRODUCTION TAPPING UNITS

BANT-A-MATIC CLUTCH-TYPE TAPERS - 8246 SERIES (Thru-hole and blind tapping)												
0.185	41	M5	50	7	900	550						
PAR-A-MATIC CLUTCH-TYPE TAPERS - 8256 SERIES (Thru-hole and blind tapping)												
0.370	77	M8	50	11	1450	850					500	
PAR-A-MATIC JAW-TYPE TAPERS - 8257 SERIES (Thru-hole)												
0.370	77	M8	50	11	1450	850					500	

Machining Tools and Standard Accessories

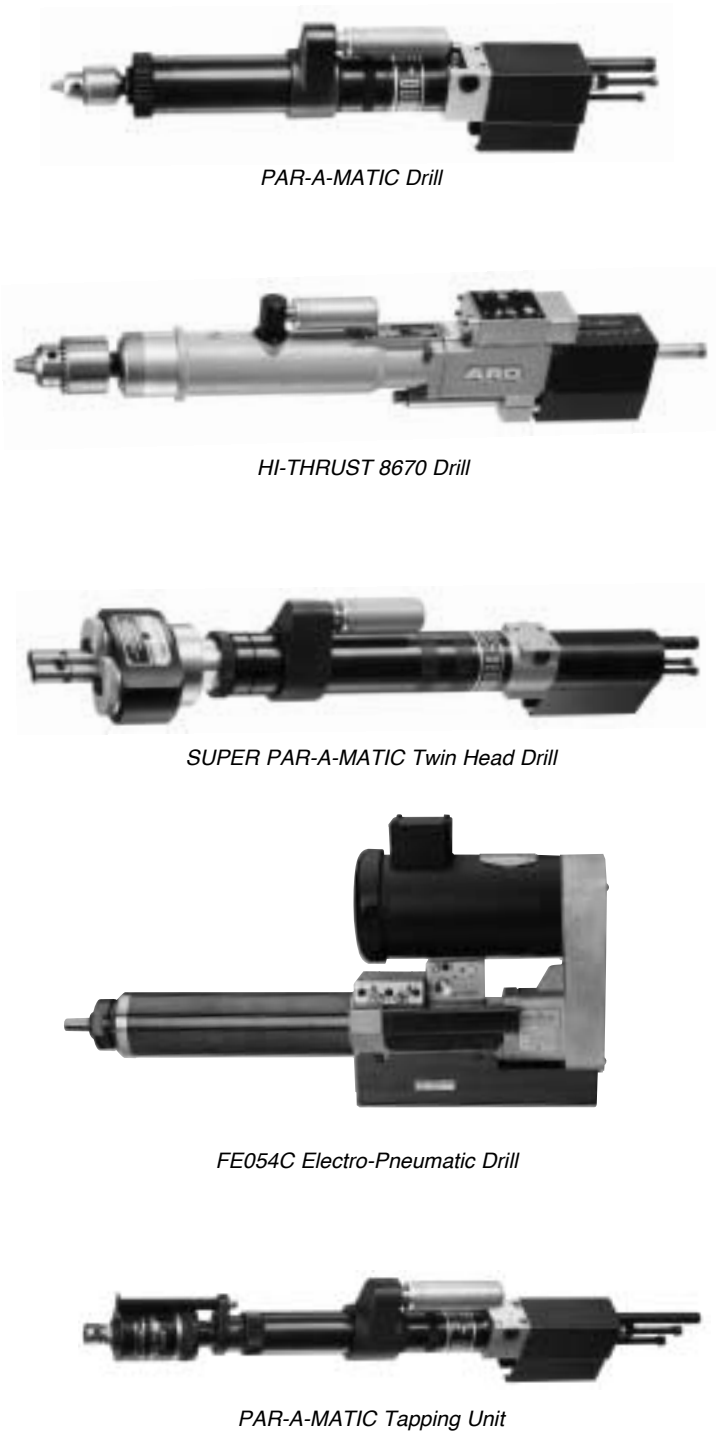

Spindle Accessories

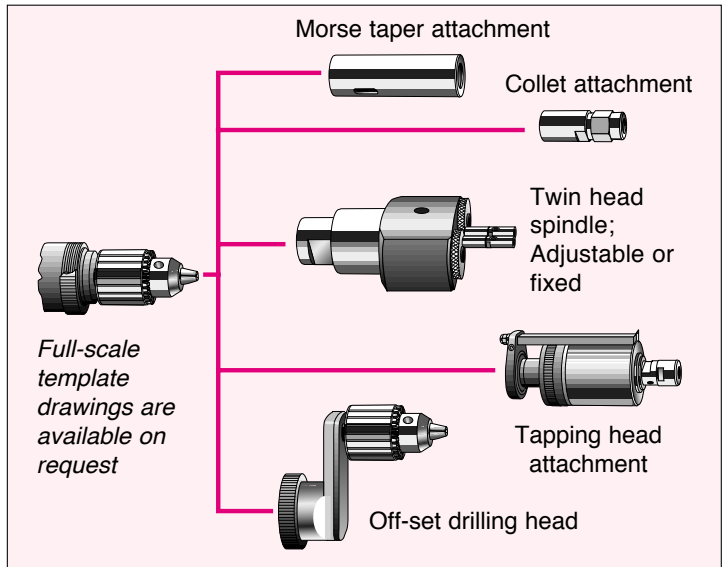

Mounting Accessories

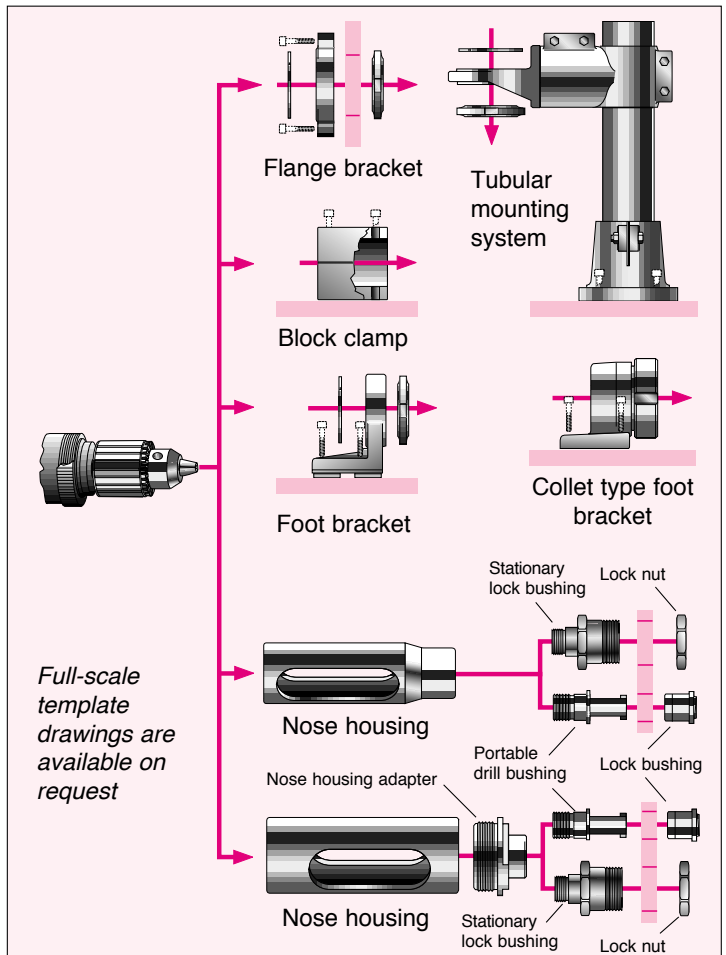

BANT-A-MATIC Pneumatic Units

Drilling Version

BANT-A-MATIC



Model No. 8245-B30

Model No. ⁽¹⁾	Max. Stroke (mm)	Free Speed (rpm)	Nominal Drilling Capacity (mm)			Air Consumption (l/sec.)	Sound Level (dBA)	Gear Reduction	Unit Weight (kg)
			Steel	Aluminium	Wood				
8245-203-3EU ⁽²⁾	76	19000	0.5	0.8	1.6	7	77	single	2.2
8245-101-3EU	76	10000	0.8	1.6	3.2	7	77	double	2.5
8245-B45-3EU	76	4400	1.6	3.2	4.0	7	77	single	2.2
8245-B30-3EU	76	2700	3.2	4.8	4.8	7	77	single	2.2
8245-B8-3EU	76	900	4.8	6.4	7.9	7	77	double	2.5

(1) These are "valve in head" models – Fitted as standard with 6.5 mm capacity chuck.

(2) This model is also available as "thru-head" tool (require an external 4-way valve for controls) and carry model no. **8345-203EU**

Dimensions (mm)

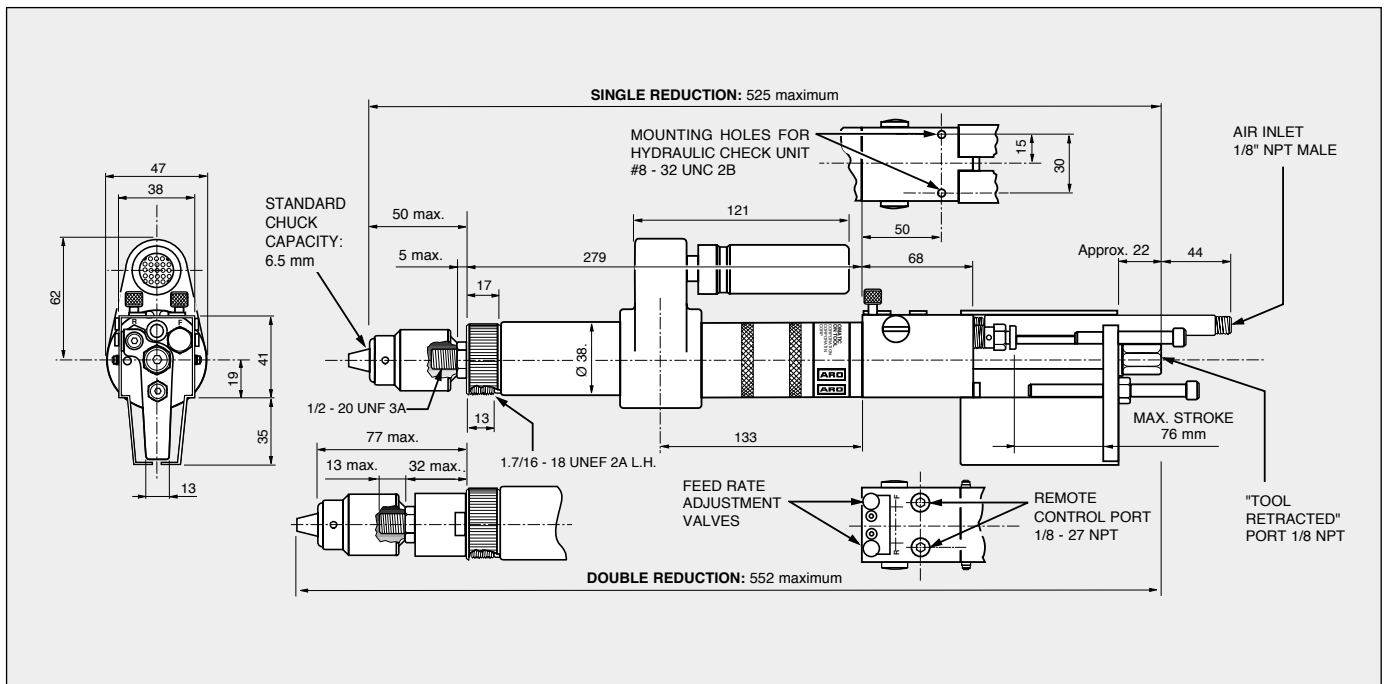

BANT-A-MATIC Pneumatic Units

Adjustable Twin Head Spindle Version



Model No. 8248-B30

Model No. ⁽¹⁾	Max. Stroke (mm)	Free Speed (rpm)	Nominal Drilling Capacity (mm)			Air Consumption (l/sec.)	Sound Level (dBA)	Gear Reduction	Unit Weight (kg)
			Steel	Aluminium	Wood				
8248-B45-3EU	76	4400	1.6	2.4	2.4	7	77	single	3.2
8248-B30-3EU	76	2700	2.4	3.2	3.2	7	77	single	3.2
8248-B8-3EU	76	900	3.2	4.8	4.8	7	77	double	3.4

(1) These are "valve in head" models.

Dimensions (mm)

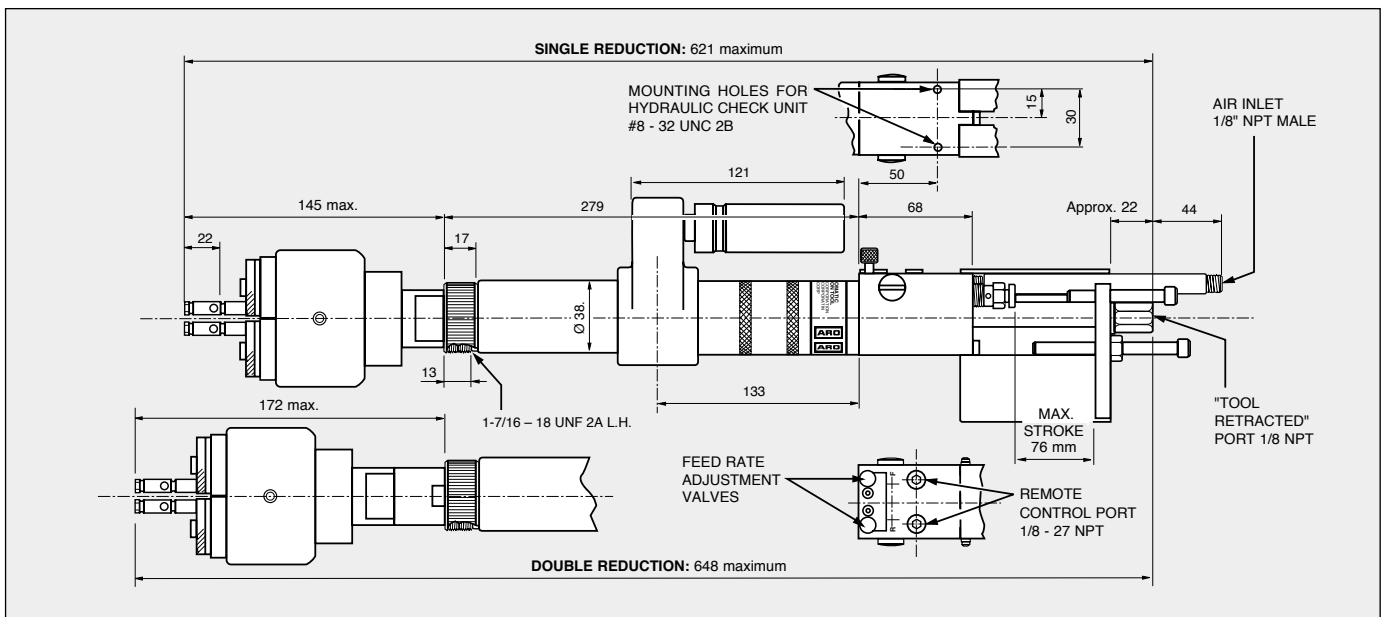

Twin Head Collets

Bore Diameter (mm)	Part no.	Bore Diameter (mm)	Part no.	Bore Diameter (mm)	Part no.	Bore Diameter (mm)	Part no.
1.0	47368-1	1.8	47368-9	2.6	47368-17	3.4	47368-25
1.1	47368-2	1.9	47368-10	2.7	47368-18	3.5	47368-26
1.2	47368-3	2.0	47368-11	2.8	47368-19	3.6	47368-27
1.3	47368-4	2.1	47368-12	2.9	47368-20	3.7	47368-28
1.4	47368-5	2.2	47368-13	3.0	47368-21	3.8	47368-29
1.5	47368-6	2.3	47368-14	3.1	47368-22	3.9	47368-30
1.6	47368-7	2.4	47368-15	3.2	47368-23	4.0	47368-31
1.7	47368-8	2.5	47368-16	3.3	47368-24		

BANT-A-MATIC Pneumatic Units

Tapping Version

BANT-A-MATIC



Model No. 8246-D8

Model No. ⁽¹⁾	Max. Stroke (mm)	Free Speed (rpm)	Nominal Tapping Capacity (mm) Mild Steel	Air Consumption (l/sec.)	Sound Level (dBA)	Unit Weight (kg)
8246-D8-2EU	50	900	M4	7	77	3.3
8246-D5-2EU	50	550	M5	7	77	3.3

(1) These are "valve in head" models – Fitted as standard with 1.6 - 6 mm capacity tapping head.

Dimensions (mm)

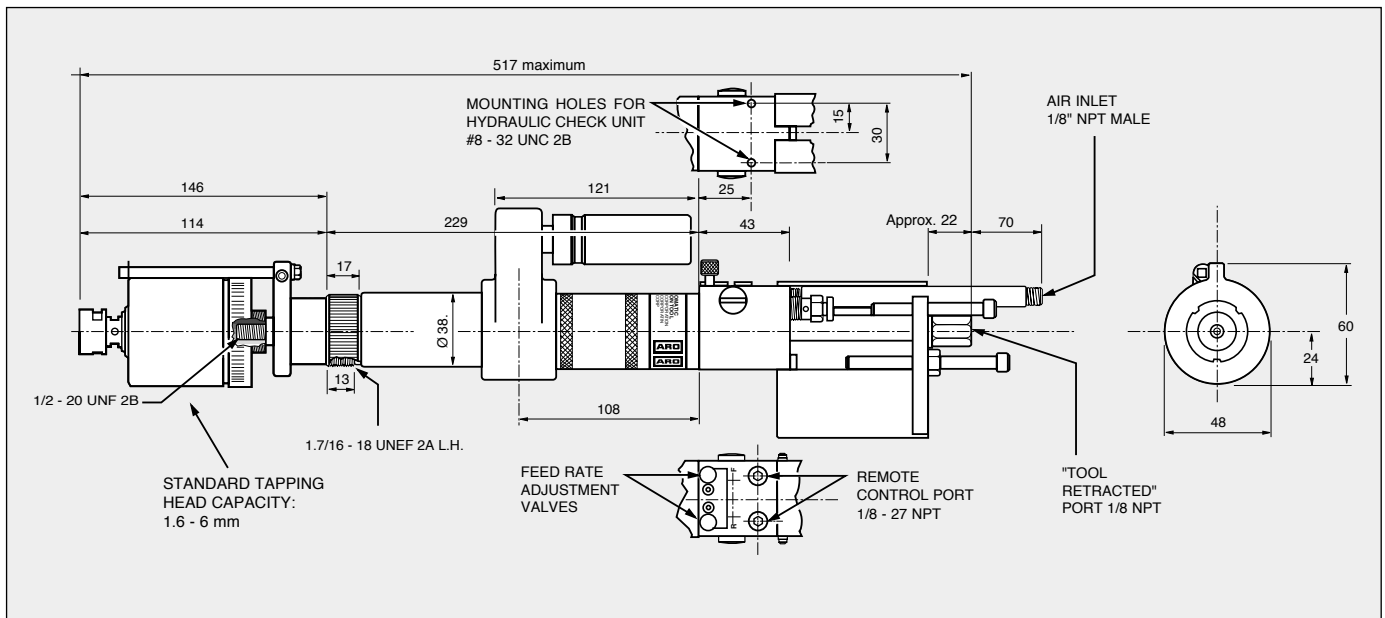

BANT-A-MATIC Pneumatic Units

Spindle Accessories

Hydraulic Check Unit

25 mm Stroke			51 mm Stroke			76 mm Stroke			Check Dia. (mm)
Check Assembly*	Check only	Overall Length (mm)	Check Assembly*	Check only	Overall Length (mm)	Check Assembly*	Check only	Overall Length (mm)	
40301-2	38922	200	40301-3	38922-1	276	40301-4	38922-2	352	24

* Hydraulic check assemblies come complete with check and mounting bracket. For mounting bracket only use part no. 40298



Drill Chuck

Drill Chuck No.*	Size Range (mm)	Thread Size	Body Length min. / max. (mm)	Cutting Tool Penetration (mm)	Outside Dia. (mm)	Chuck Key No.
33906	0 - 6.4	1/2-20 R.H.	44.5 / 55.5	17.5	33.5	30209-K

* Includes chuck key.



Taper Shank Adapter

Morse Taper No.	Part No.	Female Thread Size	Length (mm)	Outside Diameter (mm)
1	35211	1/2-20	89	25.4
2	31394	1/2-20	101.5	25.4



Collet Attachment

Collet Part No.	Size Range (mm) Min. / Max.	Insert
41758-1	0.4 / 1.2	31812-1
41758-2	1.2 / 2.0	31812-2
41758-3	2.0 / 2.4	31812-3
41758-4	2.4 / 3.2	31812-4
41758-5	3.2 / 4.0	31812-5
41758-6	4.0 / 4.8	31812-6
41758-7	4.8 / 5.5	31812-7
41758-8	5.5 / 6.3	31812-8

SUB-ASSEMBLIES:

- Body 41756
- Nut 32541

SPECIFICATIONS:

- Length 65 mm
- Female thread 1/2" - 20
- Outside diameter 19 mm
- Cutting tool penetration 33 mm



Twin Head Drill Attachment (For details of twin head collets, see page 7)

Complete Head Assembly	Head only	Adapter only	Application	Adj. Spindle Centre distance Min. (mm)	Max. (mm)
46394	48057-1	48056-1	Drilling	9.5	54
48060-1	48057-1	48058-1	Tapping	9.5	54



Tapping Head Attachment (Includes torque arm)

Tapping Attachment	Tapping Capacity	Rubber Flex Insert	Cutting tool penetration (mm)	Length (mm)	Outside diameter (mm)
42123-1	M6	37431-2	17	108	48



BANT-A-MATIC Pneumatic Units

Mounting Accessories

BANT-A-MATIC

Flange Bracket

Part no. **39486** (includes nut)

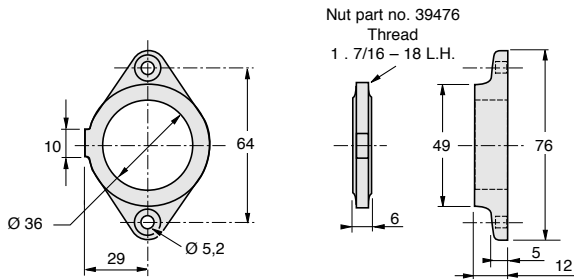

Foot Bracket

Part no. **39485-1** (includes nut)

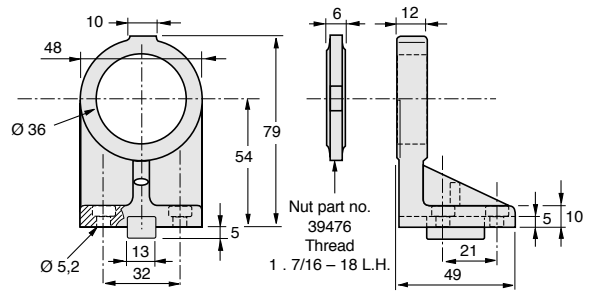

Block Clamp

Part no. **36042**

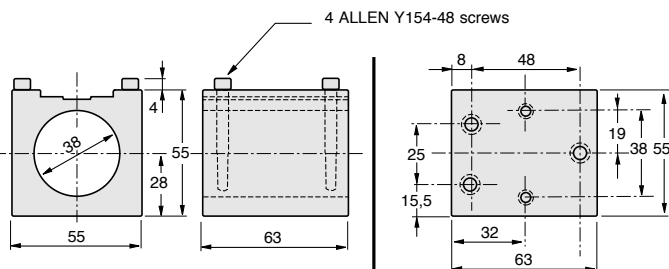

Tool Mount Assembly

Part no. **43786-1** (See mounting system diagrams page 24)

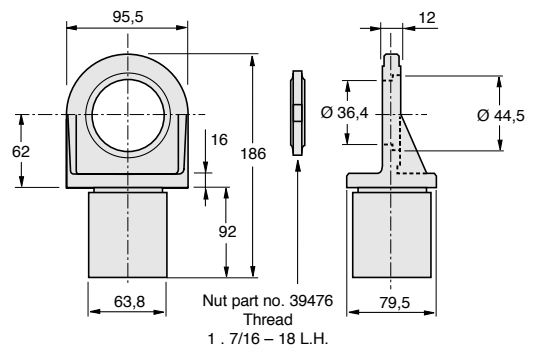

BANT-A-MATIC Pneumatic Units

Mounting Accessories (cont)

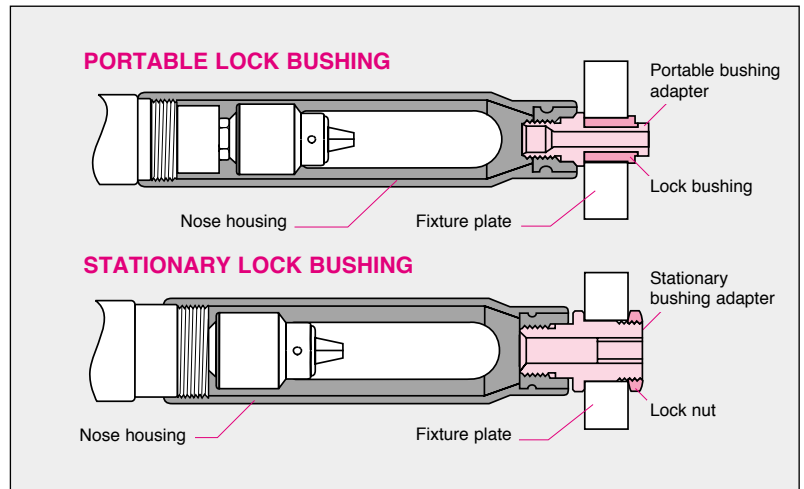

BANT-A-MATIC

Nose Housings

Compatible Drill Models	Nose Housing Part No.	Thread Sizes		Length (mm) C	Diameter (mm)			Dim. (mm)	
		A To Tool	B To Bush Adapter		OD1	OD2	ID	E	F
8245-202-3 EU 8245-101-3 EU 8245-B45-3 EU 8245-B30-3 EU	35917	1.7/16" 18 UNEF-2B L.H.	3/4" 16 UNF-2B L.H.	163	41	36	33	28	122
8245-B8-3 EU	40804	1.7/16" 18 UNEF-2B L.H.	3/4" 16 UNF-2B L.H.	191	41	36	33	28	152

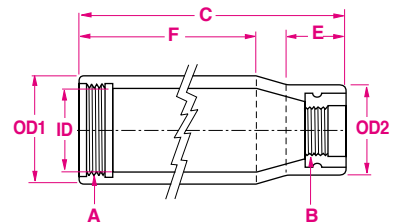

Portable Drill Bushing Adapters

Drill Bushing Adapter Part No.	Bore Dia. min. / max. (mm)	Interior Bush Dia. (mm) +0,03 -0,00	Lock Bushing* Part No.	Thread Size to Nose Housing A	Dimensions (mm)		Lock Bushing Dia. "D" (mm) +0,03 -0,03
					B	C	
35214	0.35 / 2.5	5.17	35215	3/4"	55.1	19	17.4
35216	2.5 / 3.5	6.36	35217	16 UNF-2A L.H.	55.1	19	19.0
35218	3.2 / 4.9	7.95	35219		55.1	19	20.6

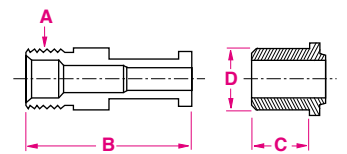

* Note: Portable drill bushing and lock bushing must be ordered separately.

Stationary Drill Bushing Adapters

Drill Bushing Adapter Part No.	Bore Dia. min. / max. (mm)	Interior Bush Dia. (mm) +0,01 -0,00	Lock Nut* Part No.	Thread Size to Nose Housing A	Thread Size to Lock Nut B	Dimensions (mm)		
						C	D	E
36646	0.35 / 2.5	5.17	38850 (1.1/2" hex.)	3/4"	1.1/4"	20.6	31.7	51
36647	2.5 / 3.5	6.36						
36648	3.2 / 4.9	7.95						
36649	4.8 / 8.0	12.7						

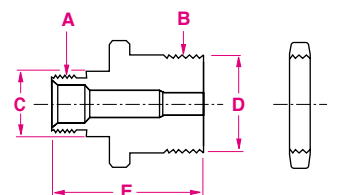

* Note: Stationary drill bushing and lock nut must be ordered separately.

PAR-A-MATIC Pneumatic Units

Drilling Version



Model No. 8255-A14

PAR-A-MATIC

Model No. ⁽¹⁾	Max. Stroke (mm)	Free Speed (rpm)	Nominal Drilling Capacity (mm)			Air Consumption (l/sec.)	Sound Level (dBA)	Gear Reduction	Unit Weight (kg)
			Steel	Aluminium	Wood				
STANDARD MODELS									
8255-172-3EU	76	17000	0.4	0.8	1.6	11	74	single	4.3
8255-101-3EU	76	10000	0.8	1.6	4.0	11	74	double	4.3
8255-A50-3EU ⁽²⁾	76	5000	2.0	4.8	4.8	11	74	single	4.3
8255-A28-3EU ⁽²⁾	76	2800	3.6	6.4	6.4	11	74	single	4.3
8255-A21-3EU	76	2100	5.6	7.1	7.9	11	74	single	4.3
8255-A14-3EU	76	1450	6.4	7.9	9.5	11	74	double	4.3
8255-A8-3EU	76	850	7.1	8.3	9.9	11	74	double	4.3
8255-A5-3EU	76	500	7.9	8.7	10.3	11	74	double	4.3
OFFSET DRILLS									
8266-A23-2EU	51	2300	1.6	3.2	4.8	11	74	double	3.9
8266-A17-2EU	51	1750	2.4	4.0	5.6	11	74	double	3.9
8266-A12-2EU	51	1200	4.0	4.8	6.4	11	74	double	3.9
8266-A7-2EU	51	700	4.8	5.6	7.2	11	74	double	3.9

(1) These are "valve in head" models – Fitted as standard with 8 mm capacity chuck.

(2) These are also available as "thru-head" tools (require an external 4-way valve for controls) and carry model no. 8355-A50-3EU and 8355-A28-3EU

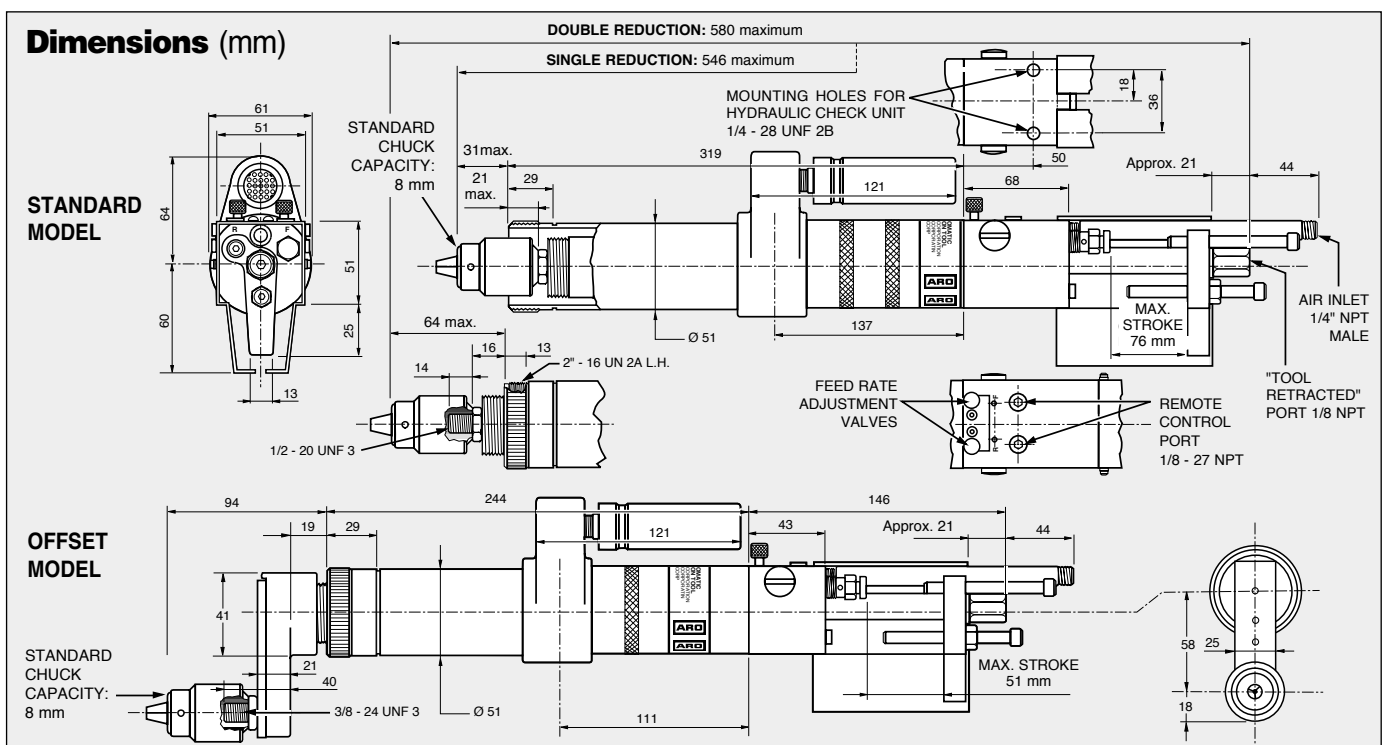

PAR-A-MATIC Pneumatic Units

Peck Feed Drill Version



Model No. 8360-A21

PAR-A-MATIC

Model No. ⁽¹⁾	Speed (rpm)	Reduction	Standard Features
8360-A172-3EU	17000	Single	<ul style="list-style-type: none"> • Max. stroke (adjustable): 75 mm. • Hydraulic check, 75 mm stroke, included. • The pecking operation is controlled by a pre-set timed sequence from 0 to 10 seconds. • Built-in control valves. • Air output signal when tool is retracted. • Remote cycle start and emergency stop ports available as standard.
8360-A50-3EU	5000	Single	
8360-A28-3EU	2800	Single	
8360-A21-3EU	2100	Single	
8360-A14-3EU	1450	Double	
8360-A8-3EU	850	Double	
8360-A5-3EU	500	Double	

(1) Fitted as standard with 8 mm capacity chuck.

Dimensions (mm)

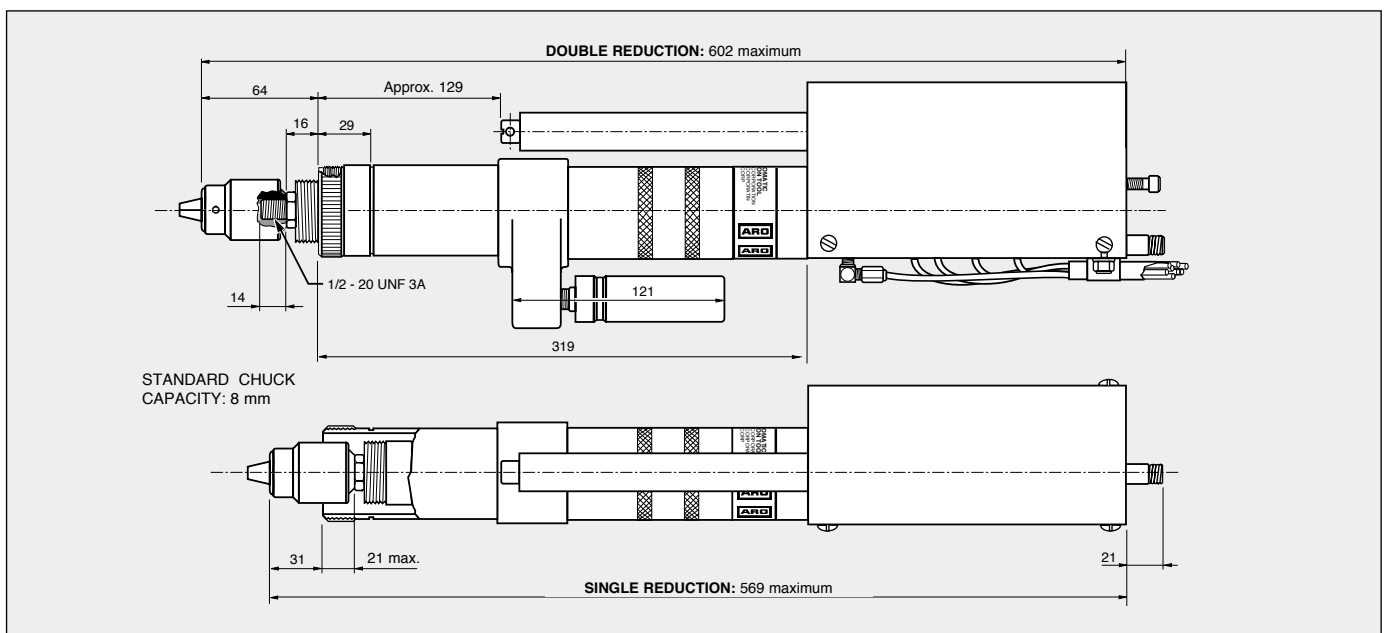

PAR-A-MATIC Pneumatic Units

Adjustable Twin Head Spindle Version



Model No. 8258-C14

PAR-A-MATIC

Model No. ⁽¹⁾	Max. Stroke (mm)	Free Speed (rpm)	Nominal Drilling Capacity (mm)			Air Consumption (l/sec.)	Sound Level (dBA)	Gear Reduction	Unit Weight (kg)
			Steel	Aluminium	Wood				
8258-C50-3EU	76	5000	1.6	3.2	3.2	11	74	single	5.3
8258-C28-3EU	76	2800	3.2	4.5	4.5	11	74	single	5.3
8258-C21-3EU	76	2100	4.0	5.6	5.6	11	74	single	5.3
8258-C14-3EU	76	1450	4.5	6.4	6.4	11	74	double	5.3
8258-C8-3EU	76	850	6.4	7.1	7.1	11	74	double	5.3
8258-C5-3EU	76	500	6.4	7.9	7.9	11	74	double	5.3

(1) These are "valve in head" models.

Dimensions (mm)

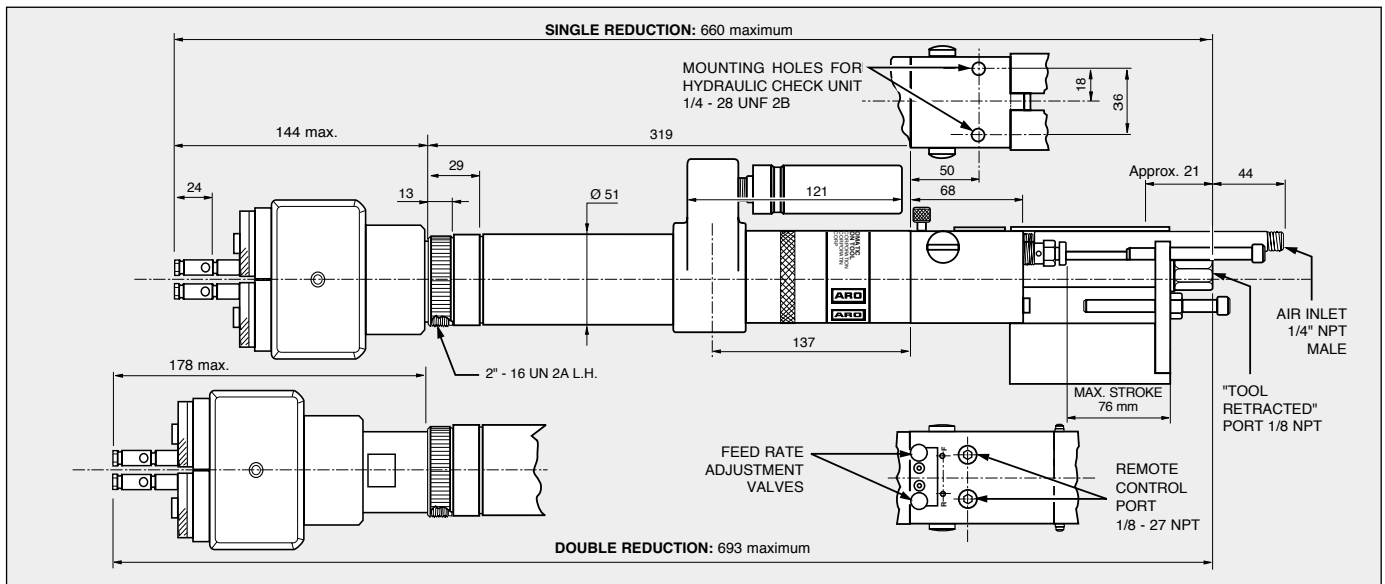

Twin Head Collets

Bore Diameter (mm)	Part No.	Bore Diameter (mm)	Part No.	Bore Diameter (mm)	Part No.	Bore Diameter (mm)	Part No.	Bore Diameter (mm)	Part No.	Bore Diameter (mm)	Part No.
1.0	45998-1	2.0	45998-11	3.0	45998-21	4.0	45998-31	5.0	45998-41	6.0	45998-51
1.1	45998-2	2.1	45998-12	3.1	45998-22	4.1	45998-32	5.1	45998-42	6.1	45998-52
1.2	45998-3	2.2	45998-13	3.2	45998-23	4.2	45998-33	5.2	45998-43	6.2	45998-53
1.3	45998-4	2.3	45998-14	3.3	45998-24	4.3	45998-34	5.3	45998-44	6.3	45998-54
1.4	45998-5	2.4	45998-15	3.4	45998-25	4.4	45998-35	5.4	45998-45	6.4	45998-55
1.5	45998-6	2.5	45998-16	3.5	45998-26	4.5	45998-36	5.5	45998-46	6.5	45998-56
1.6	45998-7	2.6	45998-17	3.6	45998-27	4.6	45998-37	5.6	45998-47		
1.7	45998-8	2.7	45998-18	3.7	45998-28	4.7	45998-38	5.7	45998-48		
1.8	45998-9	2.8	45998-19	3.8	45998-29	4.8	45998-39	5.8	45998-49		
1.9	45998-10	2.9	45998-20	3.9	45998-30	4.9	45998-40	5.9	45998-50		

PAR-A-MATIC Pneumatic Units

Tapping Version



Model No. 8257-A8

PAR-A-MATIC pneumatic self feed tapers are available with 2 different head types:

- Clutch-type for thru-hole and blind tapping.
- Jaw-type for thru-hole only.

Model No. ⁽¹⁾	Max. Stroke (mm)	Free Speed (rpm)	Nominal Tapping Capacity (mm) Mild Steel	Air Consumption (l/sec.)	Sound Level (dBA)	Unit Weight (kg)
FOR THRU-HOLE & BLIND TAPPING						
8256-C14-2EU	50	1450	M5	11	74	4.9
8256-C8-2EU	50	850	M6	11	74	4.9
8256-C5-2EU	50	500	M8	11	74	4.9
FOR THRU-HOLE TAPPING						
8257-A14-AEU	50	1450	M5	11	74	4.6
8257-A8-AEU	50	850	M6	11	74	4.6
8257-A5-AEU	50	500	M8	11	74	4.6

(1) These are "valve in head" models.

Dimensions (mm)

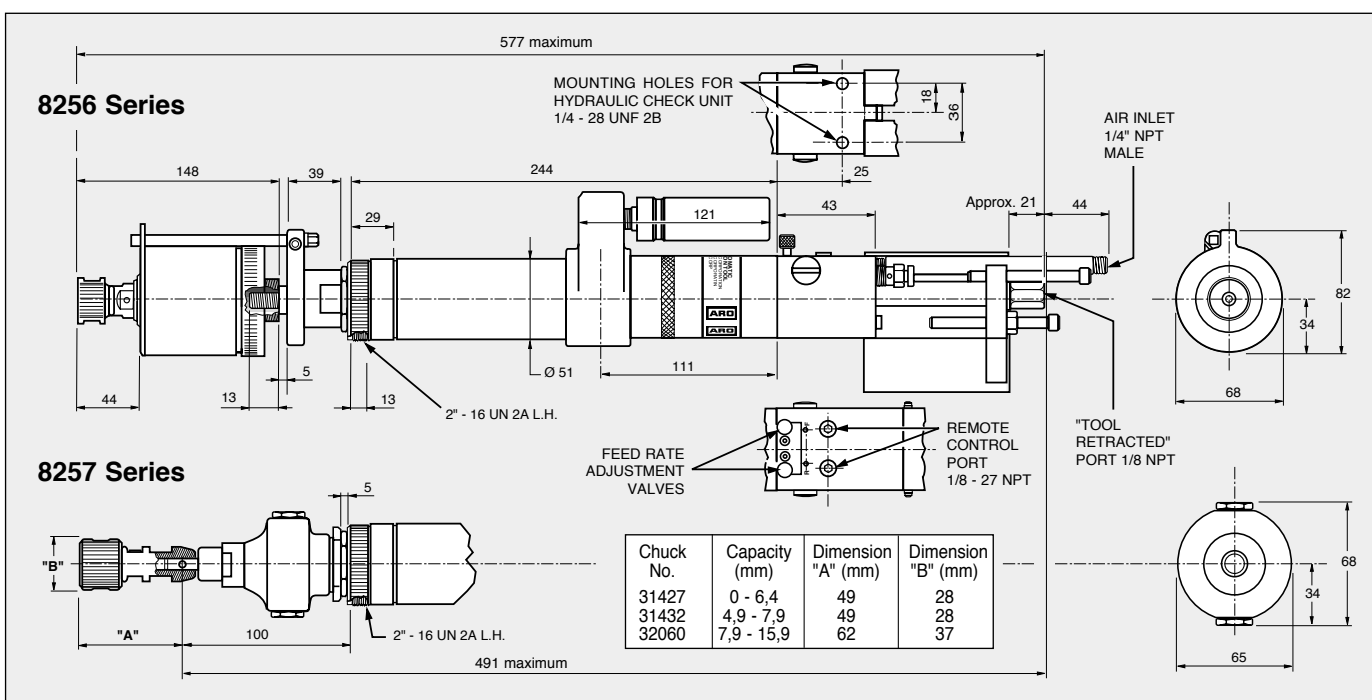

PAR-A-MATIC Pneumatic Units

Spindle Accessories

Hydraulic Check Unit

25 mm Stroke			51 mm Stroke			76 mm Stroke			Check Dia. (mm)
Check Assembly*	Check only	Overall Length (mm)	Check Assembly*	Check only	Overall Length (mm)	Check Assembly*	Check only	Overall Length (mm)	
40591-3	38922	200	40591-4	38922-1	276	40591-5	38922-2	352	24

* Hydraulic check assemblies come complete with check and mounting bracket. For mounting bracket only use part no. 40316



Drill Chuck

Drill Chuck No.*	Size Range (mm)	Thread Size	Body Length min. / max. (mm)	Cutting Tool Penetration (mm)	Outside Dia. (mm)	Chuck Key No.
33907	1.6 - 9.5	1/2-20 R.H.	49 / 61	20.6	36	30510-K

* Includes chuck key.



Offset Drilling Head

To convert a standard drill into an offset drill, order the following parts:

- 1 offset drill attachment, part no. 42797-1
- 2 spacers, part no. 30756-2
- 3 washers, part no. 32310
- 1 chuck, part no. 47341 or collet:
 - Part no. 39959-1 (from 2.4 to 3.7 mm)
 - Part no. 39959-2 (from 3.7 to 5 mm)
 - Part no. 39959-3 (from 5 to 6.4 mm)



See dimensions page 12

Taper Shank Adapter

Morse Taper No.	Part No.	Female Thread Size	Length (mm)	Outside Diameter (mm)
1	35211	1/2-20	89	25.4
2	31394	1/2-20	101.5	25.4



Collet Attachment

Collet Part No.	Size Range (mm) Min. / Max.	Insert	Collet Part No.	Size Range (mm) Min. / Max.	Insert
41758-1	0.4 / 1.2	31812-1	35074-1	5.5 / 6.4	35264-1
41758-2	1.2 / 2.0	31812-2	35074-2	6.4 / 7.1	35264-2
41758-3	2.0 / 2.4	31812-3	35074-3	7.1 / 7.9	35264-3
41758-4	2.4 / 3.2	31812-4	35074-4	7.9 / 8.7	35264-4
41758-5	3.2 / 4.0	31812-5	35074-5	8.7 / 9.5	35264-5
41758-6	4.0 / 4.8	31812-6	35074-6	9.5 / 10.3	35264-6
41758-7	4.8 / 5.5	31812-7			
41758-8	5.5 / 6.3	31812-8			

SPECIFICATIONS:

- Length 65 mm
- Outside diameter 19 mm
- Female thread 1/2"
- Cutting tool penetration 33 mm

SPECIFICATIONS:

- Length 82.5 mm
- Outside diameter 51.5 mm
- Female thread 1/2"
- Cutting tool penetration 47.5 mm



PAR-A-MATIC Pneumatic Units

Accessories (cont)

Tapping Chuck

Part No.	Capacity (mm)	Mounting Style	Length min. / max. (mm)	Cutting Tool Penetration (mm)	Outside Diameter	Rubber Flex Insert
31427	M1.6 - M6	9.3 mm	60 / 64	25.4 - 29.8	27.5	31437
31432	M4.5 - M8	9.3 mm	59 / 64	25.4 - 29.8	27.5	31436
32060	M7 - M16	9.3 mm	73 / 80	27.8 - 35	37	32061



Tapping Head Attachment (Includes torque arm)

Tapping Attachment	Tapping Capacity	Rubber Flex Inserts	Cutting tool penetration (mm)	Length (mm)	Outside diameter (mm)
38021-4	M1.6 - M6 M6 - M12	38036 38036-1	31	147	70



Twin Head Drill Attachment (For details of twin head collets, see page 14)

Complete Head Assembly	Head only	Adapter only	Application	Adj. Spindle Centre distance Min. (mm)	Max. (mm)
46023	47980	47283	Drilling	12.7	63.5
48055	47980	47982	Tapping	12.7	63.5



Mounting Accessories

Foot Bracket

Part no. 38875-1 (includes nut)

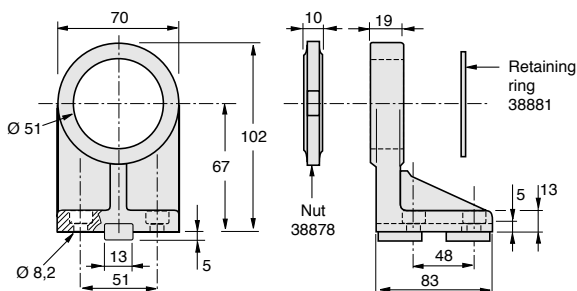

Flange Bracket

Part no. 38877 (includes nut)

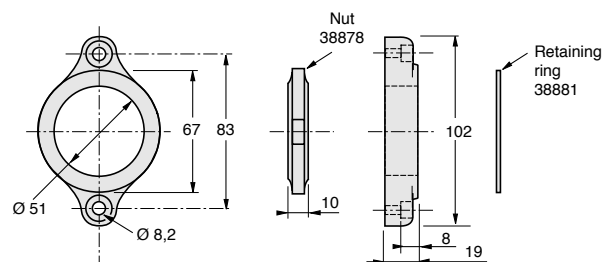

Block Clamp - Part no. 35283

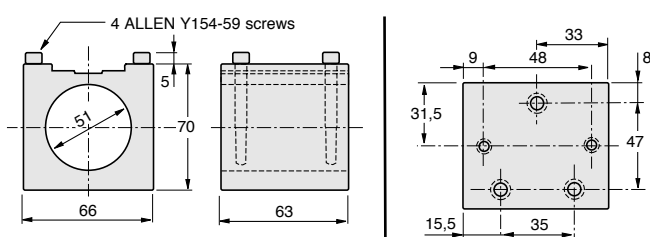

Tool Mount Assembly

Part no. 43786-2

(See mounting system diagrams page 24)

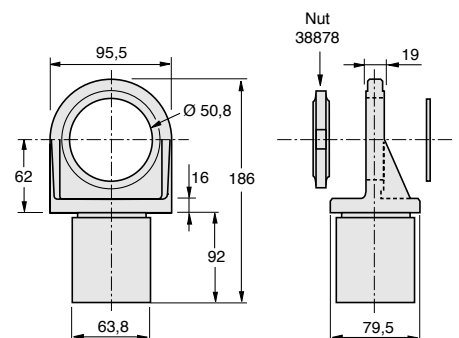

PAR-A-MATIC Pneumatic Units

Mounting Accessories (cont)

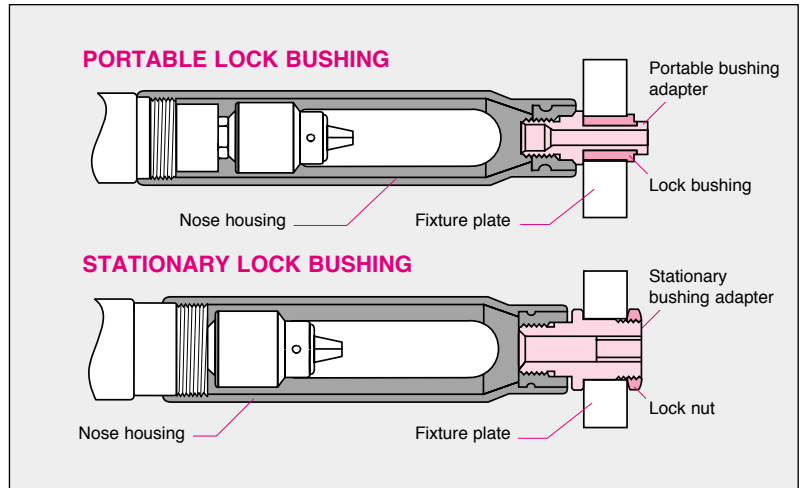

Nose Housings

Compatible Drill Models	Nose Housing Part No.	Thread Sizes		Length (mm) C	Diameter (mm)			Dim. (mm)	
		A To Tool	B To Bush Adapter		OD1	OD2	ID	E	F
8255-171-3EU 8255-101-3EU 8255-A50-3EU 8255-A28-3EU 8255-A21-3EU	38852 or 38853 or 38854	2"-16 UN-2B L.H.	3/4"-16 UNF-2B L.H.	155	56	48	44	28	112
8255-A14-3EU 8255-A8-3EU 8255-A5-3EU	40810 or 40811 or 40812	2"-16 UN-2B L.H.	1"-14 UNF-2B L.H.						
		2"-16 UN-2B L.H.	1.1/4"-12 UNF-2B L.H.						
		2"-16 UN-2B L.H.	1"-14 UNF-2B L.H.						
		2"-16 UN-2B L.H.	1.1/4"-12 UNF-2B L.H.						

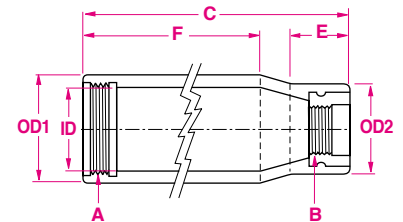

Portable Drill Bushing Adapters

Drill Bushing Adapter Part No.	Bore Dia. min. / max. (mm)	Interior Bush Dia. (mm) +0,03 -0,00	Lock Bushing* Part No.	Thread Size to Nose Housing A	Dimensions (mm) B C	Lock Bushing Dia. "D" (mm) +0,03 -0,03
35214	0.35 / 2.5	5.17	35215	3/4"	55.1 19.0	17.4
35216	2.5 / 3.5	6.36	35217	16 UNF-2A L.H.	55.1 19.0	19.0
35218	3.2 / 4.9	7.95	35219		55.1 19.0	20.6
35220	4.8 / 8.0	12.7	35221	1"-14 UNF-2A L.H.	55.9 19.0	25.4
35222	8.0 / 13.5	19.0	35223	1.1/4"-12 UNF-2A L.H.	55.9 25.4	34.9

* Note: Portable drill bushing and lock bushing must be ordered separately.

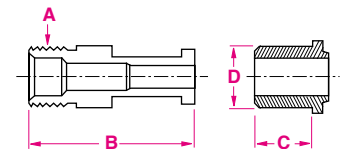

Stationary Drill Bushing Adapters

Drill Bushing Adapter Part No.	Bore Dia. min. / max. (mm)	Interior Bush Dia. (mm) +0,01 -0,00	Lock Nut* Part No.	Thread Size to Nose Housing A	Thread Size to Lock Nut B	Dimensions (mm) C D E
36646	0.35 / 2.5	5.17	38850	3/4"	1.1/4"	20.6 31.7 51
36647	2.5 / 3.5	6.40		16 UNF-2A L.H.	12 UNF-2A	
36648	3.2 / 4.9	7.95				
36649	4.8 / 8.0	12.7				
36650	4.8 / 8.0	12.7	38850	1"-14 UNF-2A L.H.	1.1/4"-12 UNF-2A	27.0 31.7 56
36651	8.0 / 13.5	19.0	38850	1.1/4"-12 UNF-2A L.H.	1.1/4"-12 UNF-2A	33.3 31.7 56

* Note: Stationary drill bushing and lock nut must be ordered separately.

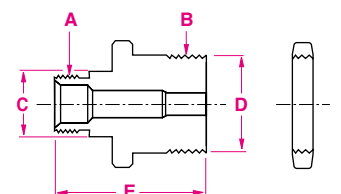

SUPER PAR-A-MATIC Pneumatic Units

Drilling Version



Model No. 8265-12

Model No. ⁽¹⁾	Max. Stroke (mm)	Free Speed (rpm)	Nominal Drilling Capacity (mm)			Air Consumption (l/sec.)	Sound Level (dBA)	Gear Reduction	Unit Weight (kg)
			Steel	Aluminium	Wood				
8265-171-3EU	76	17000	0.4	2.4	2.4	14	77	single	7.5
8265-101-3EU	76	10000	1.2	4.0	4.0	14	77	double	8
8265-46-3EU	76	4600	3.2	6.4	7.9	14	77	single	7.5
8265-25-3EU	76	2500	4.8	7.9	11.1	14	77	single	7.5
8265-12-3EU	76	1200	7.9	9.5	14.3	14	77	double	8
8265-6-3EU	76	650	11.1	14.3	15.9	14	77	double	8
8265-3-3EU	76	350	12.7	15.9	17.5	14	77	double	8

(1) These are "valve in head" models – Fitted as standard with 13 mm capacity chuck.

Dimensions (mm)

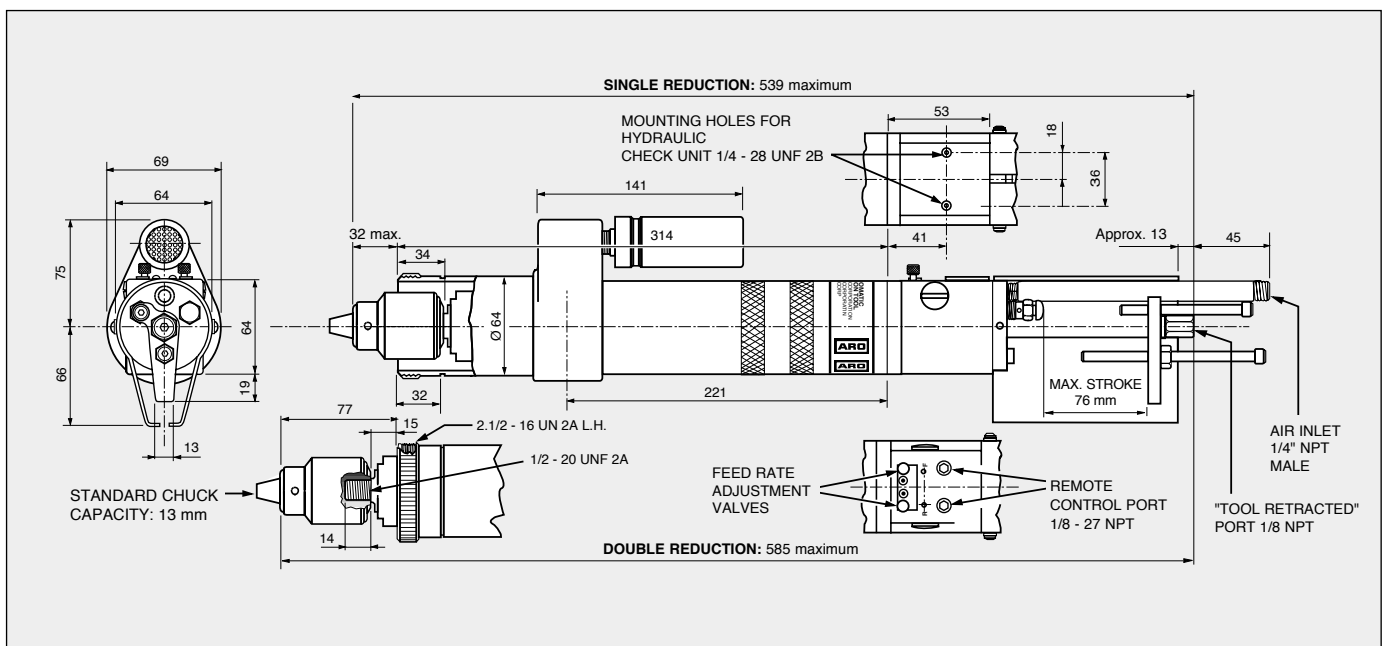

SUPER PAR-A-MATIC Pneumatic Units

Adjustable Twin Head Spindle Version



Model No. 8268-A12

Model No. ⁽¹⁾	Max. Stroke (mm)	Free Speed (rpm)	Nominal Drilling Capacity (mm)			Air Consumption (l/sec.)	Sound Level (dBA)	Gear Reduction	Unit Weight (kg)
			Steel	Aluminium	Wood				
8268-A46-3EU	76	4600	-	6.4	4.8	14	77	single	8.9
8268-A25-3EU	76	2500	6.4	7.9	7.9	14	77	single	8.9
8268-A12-3EU	76	1200	7.9	8.7	9.5	14	77	double	8.9
8268-A6-3EU	76	650	8.7	9.5	11.1	14	77	double	8.9
8268-A3-3EU	76	350	9.5	10.3	11.9	14	77	double	8.9

(1) These are "valve in head" models.

Dimensions (mm)

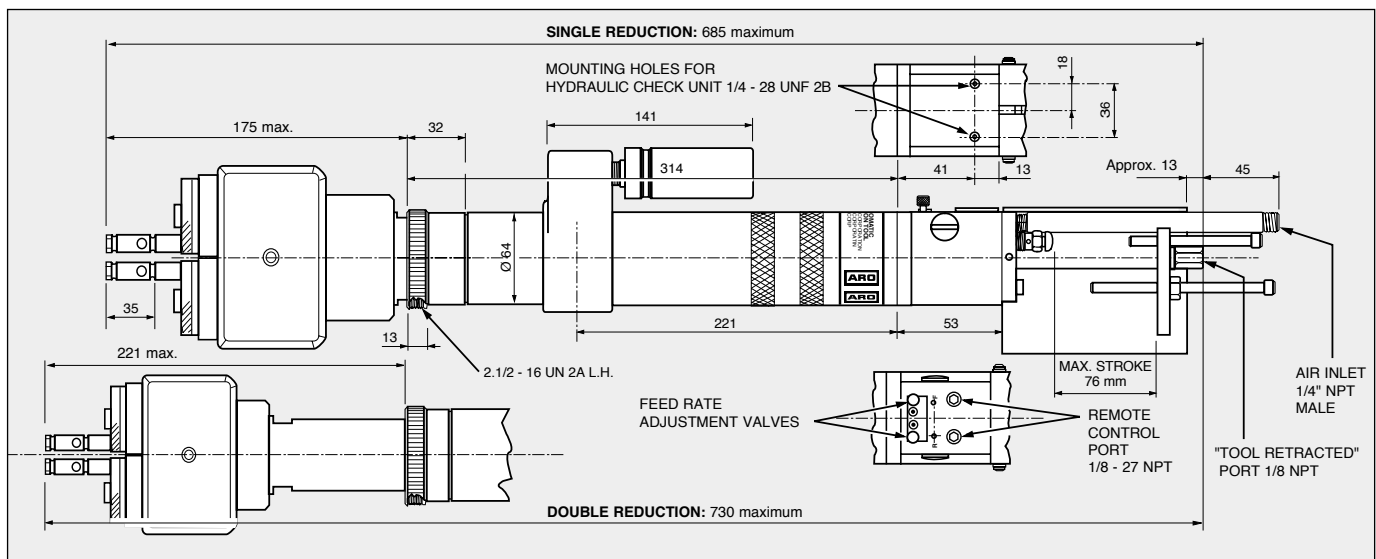

Twin Head Collets

Bore Dia. (mm)	Part no.	Bore Dia. (mm)	Part no.	Bore Dia. (mm)	Part no.	Bore Dia. (mm)	Part no.	Bore Dia. (mm)	Part no.	Bore Dia. (mm)	Part no.	Bore Dia. (mm)	Part no.
2.0	46033-1	3.1	46033-12	4.2	46033-23	5.3	46033-34	6.4	46033-45	7.5	46033-56	8.6	46033-67
2.1	46033-2	3.2	46033-13	4.3	46033-24	5.4	46033-35	6.5	46033-46	7.6	46033-57	8.7	46033-68
2.2	46033-3	3.3	46033-14	4.4	46033-25	5.5	46033-36	6.6	46033-47	7.7	46033-58	8.8	46033-69
2.3	46033-4	3.4	46033-15	4.5	46033-26	5.6	46033-37	6.7	46033-48	7.8	46033-59	8.9	46033-70
2.4	46033-5	3.5	46033-16	4.6	46033-27	5.7	46033-38	6.8	46033-49	7.9	46033-60	9.0	46033-71
2.5	46033-6	3.6	46033-17	4.7	46033-28	5.8	46033-39	6.9	46033-50	8.0	46033-61	9.1	46033-72
2.6	46033-7	3.7	46033-18	4.8	46033-29	5.9	46033-40	7.0	46033-51	8.1	46033-62	9.2	46033-73
2.7	46033-8	3.8	46033-19	4.9	46033-30	6.0	46033-41	7.1	46033-52	8.2	46033-63	9.3	46033-74
2.8	46033-9	3.9	46033-20	5.0	46033-31	6.1	46033-42	7.2	46033-53	8.3	46033-64	9.4	46033-75
2.9	46033-10	4.0	46033-21	5.1	46033-32	6.2	46033-43	7.3	46033-54	8.4	46033-65	9.5	46033-76
3.0	46033-11	4.1	46033-22	5.2	46033-33	6.3	46033-44	7.4	46033-55	8.5	46033-66		

SUPER PAR-A-MATIC Pneumatic Units

Spindle Accessories

Hydraulic Check Unit

25 mm Stroke			51 mm Stroke			76 mm Stroke			Check Dia. (mm)
Check Assembly*	Check only	Overall Length (mm)	Check Assembly*	Check only	Overall Length (mm)	Check Assembly*	Check only	Overall Length (mm)	
40591-3	38922	200	40591-4	38922-1	276	40591-5	38922-2	352	24

* Hydraulic check assemblies come complete with check and mounting bracket. For mounting bracket only use part no. 40316



Drill Chuck

Drill Chuck No.*	Size Range (mm)	Thread Size	Body Length min. / max. (mm)	Cutting Tool Penetration (mm)	Outside Dia. (mm)	Chuck Key No.
33907	1.6 - 9.5	1/2-20 R.H.	49 / 61	20.6	36	305-10-K
30018	2 - 13	1/2-20 R.H.	61.5 / 78.5	29	45.5	30016-K

* Includes chuck key.



Taper Shank Adapter

Morse Taper No.	Part No.	Female Thread Size	Length (mm)	Outside Diameter (mm)
1	35211	1/2-20	89	25.4
2	31394	1/2-20	101.5	25.4



Collet Attachment

Collet Part No.	Size Range (mm) Min. / Max.	Insert	Collet Part No.	Size Range (mm) Min. / Max.	Insert
41758-1	0.4 / 1.2	31812-1	35074-1	5.5 / 6.4	35264-1
41758-2	1.2 / 2.0	31812-2	35074-2	6.4 / 7.1	35264-2
41758-3	2.0 / 2.4	31812-3	35074-3	7.1 / 7.9	35264-3
41758-4	2.4 / 3.2	31812-4	35074-4	7.9 / 8.7	35264-4
41758-5	3.2 / 4.0	31812-5	35074-5	8.7 / 9.5	35264-5
41758-6	4.0 / 4.8	31812-6	35074-6	9.5 / 10.3	35264-6
41758-7	4.8 / 5.5	31812-7	35074-7	10.3 / 11.1	35264-7
41758-8	5.5 / 6.3	31812-8	35074-8	11.1 / 11.9	35264-8

SPECIFICATIONS:

- Length 65 mm
- Outside diameter 19 mm
- Female thread 1/2"
- Cutting tool penetration 33 mm

SPECIFICATIONS:

- Length 82.5 mm
- Outside diameter 51.5 mm
- Female thread 1/2"
- Cutting tool penetration 47.5 mm



Twin Head Drill Attachment (For details of twin head collets, see page 20)

Complete Head Assembly	Head only	Adapter only	Application	Adj. Spindle Centre distance	
				Min. (mm)	Max. (mm)
47489	47980	47490	Drilling	12.7	63.5
46063	47768	47767	Drilling	19	95
47288	47768	47282	Tapping	19	95



SUPER PAR-A-MATIC Pneumatic Units

Mounting Accessories

Flange Bracket

Part no. 40589 (includes nut)

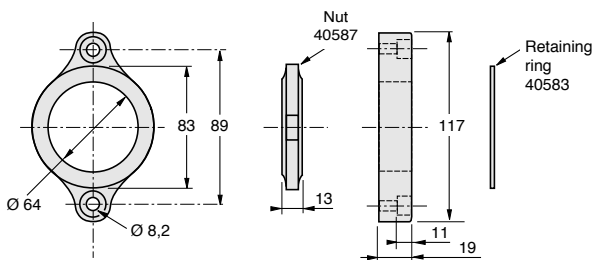

Foot Bracket

Part no. 40588-1 (includes nut)

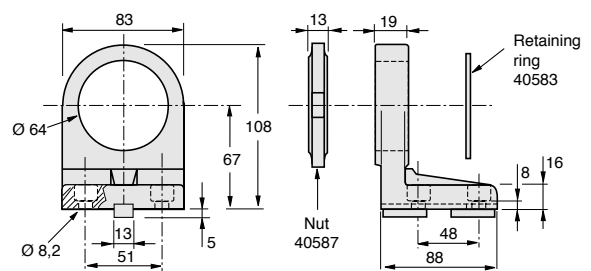

Collet Type Foot Bracket

Part no. 41454

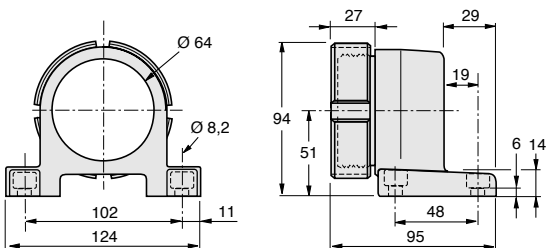

Tool Mount Assembly

Part no. 43786-3 (See mounting system diagrams page 24)

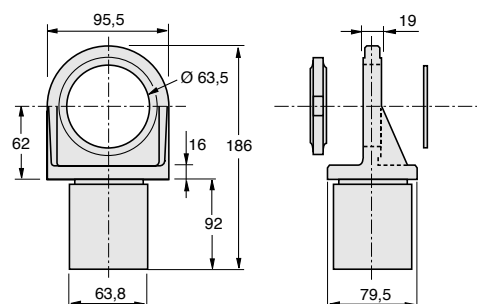

SUPER PAR-A-MATIC Pneumatic Units

Mounting Accessories (cont)

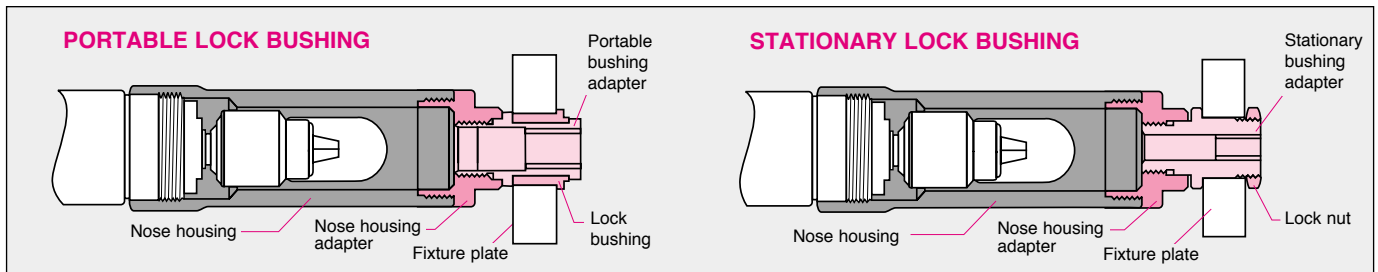

Nose Housings

Compatible Drill Models	Nose Housing Part No.	Thread Sizes		Length (mm) C	Diameter (mm)			Dim. (mm)	
		A To Tool	B To Bush Adapter		OD1	OD2	ID	E	F
8265-171-3EU 8265-101-3EU 8265-46-3EU 8265-25-3EU	40584-1	2.1/2" 16 UN-2B L.H.	2.3/8" 16 UN-2B L.H.	152	74	69	51	22	99
8265-12-3EU 8265-6-3EU 8265-3-3EU	40584-2	2.1/2" 16 UN-2B L.H.	2.3/8" 16 UN-2B L.H.	198	74	69	51	22	145

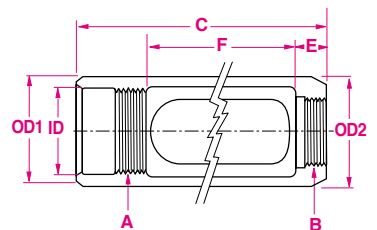

Nose Housing Adapters

Part No.	Thread Size		Dimensions (mm)
	A to Nose Housing	B to Drill Bushing Adapter	
33812	2.3/8" - 16 UN-2A L.H.	3/4" - 16 UNF-2B L.H.	C: 44, D: 22.2, E: 16, F: 47
33751	2.3/8" - 16 UN-2A L.H.	1" - 14 UNF-2B L.H.	C: 44, D: 22.2, E: 16, F: 47
33764	2.3/8" - 16 UN-2A L.H.	1.1/4" - 12 UNF-2B L.H.	C: 44, D: 22.2, E: 16, F: 47
34075	2.3/8" - 16 UN-2A L.H.	1.1/2" - 12 UNF-2B L.H.	C: 51, D: 22.2, E: 16, F: 47

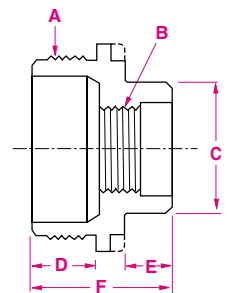

Portable Drill Bushing Adapters

Drill Bushing Adapter Part No.	Bore Dia. min. / max. (mm)	Interior Bush Dia. (mm) +0.03 -0.00	Lock Bushing* Part No.	Thread Size to Nose Housing A	Dimensions (mm)		Lock Bushing Dia. "D" (mm) +0.03 -0.03
					B	C	
35214	0.35 / 2.5	5.17	35215	3/4"	55.1	19.0	17.4
35216	2.5 / 3.5	6.36	35217	16 UNF-2A L.H.	55.1	19.0	19.0
35218	3.2 / 4.9	7.95	35219	16 UNF-2A L.H.	55.1	19.0	20.6
35220	4.8 / 8.0	12.7	35221	1"-14 UNF-2A L.H.	55.9	19.0	25.4
35222	8.0 / 13.5	19.0	35223	1.1/4"-12 UNF-2A L.H.	55.9	25.4	34.9
35224	12.7 / 19.4	25.4	35225	1.1/2"-12 UNF-2A L.H.	67.3	28.6	44.4

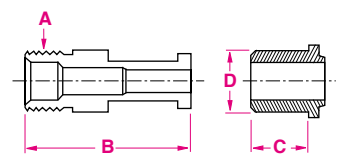

* Note: Portable drill bushing and lock bushing must be ordered separately.

Stationary Drill Bushing Adapters

Drill Bushing Adapter Part No.	Bore Dia. min. / max. (mm)	Interior Bush Dia. (mm) +0.01 -0.00	Lock Nut* Part No.	Thread Size to Nose Housing A	Thread Size to Lock Nut B	Dimensions (mm)		
						C	D	E
36646	0.35 / 2.5	5.17		3/4"				
36647	2.5 / 3.5	6.36	38850	16 UNF-2A L.H.	1.1/4"	20.6	31.7	51
36648	3.2 / 4.9	7.95		16 UNF-2A L.H.	12 UNF-2A			
36649	4.8 / 8.0	12.7						
36650	4.8 / 8.0	12.7	38850	1"-14 UNF-2A L.H.	1.1/4"-12 UNF-2A	27.0	31.7	56
36651	8.0 / 13.5	19.0	38850	1.1/4"-12 UNF-2A L.H.	1.1/4"-12 UNF-2A	33.3	31.7	56
46088	12.7 / 19.4	25.4	46089	1.1/2"-12 UNF-2A L.H.	1.5/8"-12 UNF-2A	39.9	38.0	56

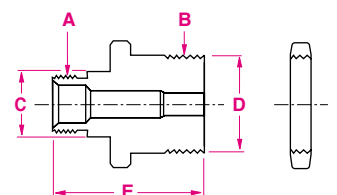

* Note: Stationary drill bushing and lock nut must be ordered separately.

Tubular Mounting System

For BANT-A-MATIC, PAR-A-MATIC & SUPER PAR-A-MATIC Series

The ARO Tubular Mounting System is an extremely versatile method of mounting ARO BANT-A-MATIC, PAR-A-MATIC and SUPER PAR-A-MATIC series tools. It allows the positioning of tools at virtually any angle to the workpiece. The following illustrations show just a few examples of the many fixture possibilities.

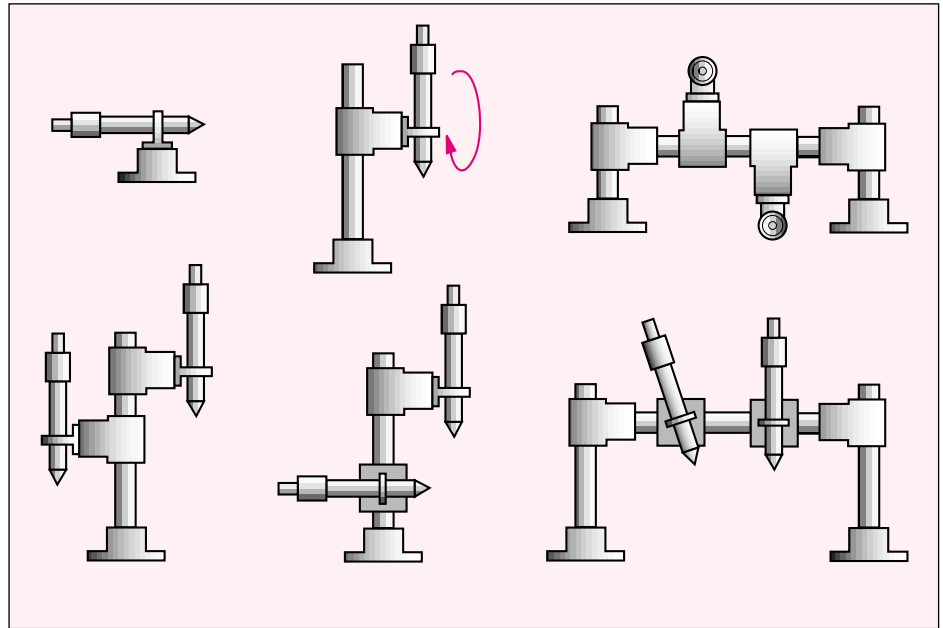
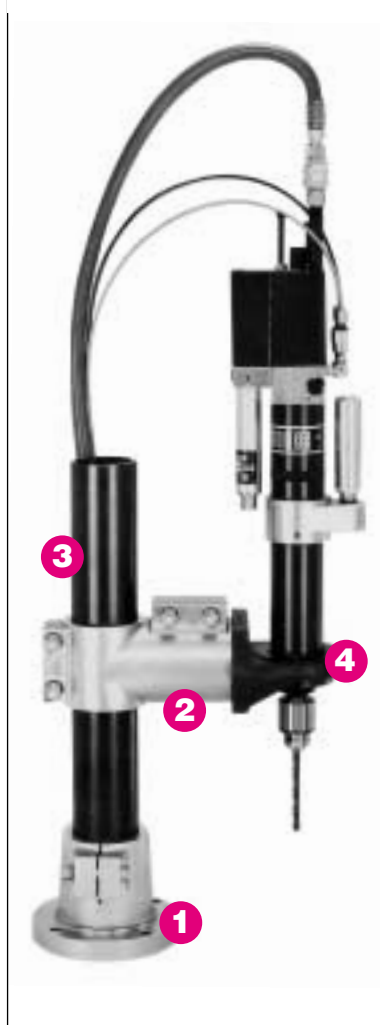

Different elements of the Tubular Mounting System

1 Base Mount Assembly - Part no. 43788

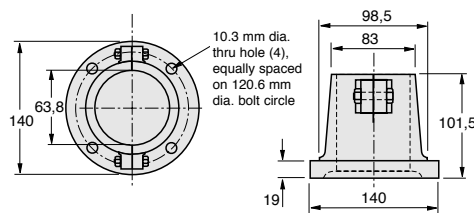

2 Coupling Assembly - Part no. 43706

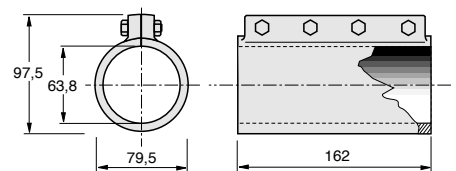

3 Mounting Tube:
Length 305 mm - Part no. 43791-12
Length 457mm - Part no. 43791-18
Length 610 mm - Part no. 43791-24

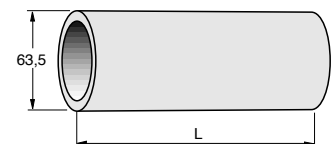

4 Tee Mount - Part no. 43790

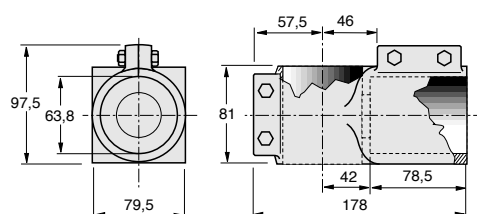

- 4** Tool Mount Assembly
- Part no. 43786-1 for BANT-A-MATIC series
 - Part no. 43786-2 for PAR-A-MATIC series
 - Part no. 43786-3 for SUPER PAR-A-MATIC series

(See dimensional support drawings in the "mounting accessories" section which details each model in the previous pages).

Control Accessories

For *BANT-A-MATIC*, *PAR-A-MATIC* & *SUPER PAR-A-MATIC* Series

Dwell Control Kit - Part no. 41729



The 41729 Dwell Control Kit is a complete, easily-installed control accessory for pneumatic ARO Automatic Feed Drills. It provides an adjustable, precisely-timed pause, or dwell, at the end of the forward stroke. The range of the dwell interval, prior to retraction, is from 0.10 to 10 seconds. Depth control for ARO Automatic Feed Drills is achieved through the use of a positive-stop adjustment screw. The addition of the dwell control is desirable for countersinking and cleanup applications.

The 41729 Dwell Control Kit may be used on any of the tool models listed in the chart:

Compatible Units →	BANT-A-MATIC	PAR-A-MATIC	SUPER PAR-A-MATIC
Unit Part No.	8245 8248	8255 8258 8266	8265 8268

Auxiliary Control Kit - Part no. 41730

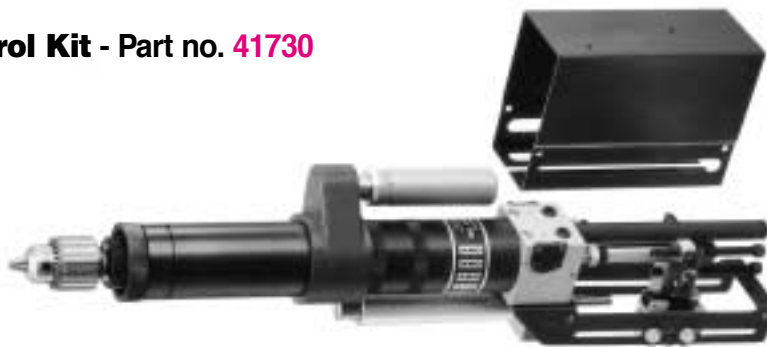

The 41730 Auxiliary Control Kit provides increased flexibility in designing automated machining systems. It can be used to generate a cycle completion signal for example, or any other desired auxiliary signal. Each kit is supplied with a miniature, three-way limit valve having a short roller lever and instant tube fittings. Additional limit valves can be installed for other functions.

The 41730 Auxiliary Control Kit may be used on any of the tool models listed in the chart:

Compatible Units →	BANT-A-MATIC	PAR-A-MATIC	SUPER PAR-A-MATIC
Unit Part No.	8245 8246 8248	8255 8256 8257 8258 8266	8265 8268

HI-THRUST 8660 & 8670 Pneumatic Units

Specifications



Model No. 8670-28

Model No. ⁽¹⁾	Max. Stroke (mm)	Free Speed (rpm)	Nominal Drilling / Tapping Capacity (mm)			Air Consumption (l/sec.)	Sound Level (dBA)	Unit Weight (kg)	Hydraulic Check ⁽²⁾	
			Steel	Aluminium	Wood				Stroke (mm)	Diameter (mm)
8660-160-3EU	76	16000	-	5	6	15	78	8.8	51	24
8660-115-3EU	76	11500	1.5	8	8	15	78	8.8		
8660-45-3EU	76	4500	2	9.5	11	15	78	8.8		
8660-27-3EU	76	2700	5	13	14	15	78	8.8		
8660-13-3EU	76	1300	8	14	17	15	78	8.8		
8660-7-3EU	76	750	11	-	21	15	78	8.8		
8660-4-3EU	76	450	13	-	25	15	78	8.8		
8670-47-3AMEU	76	4700	9.5	11	13	23	80	12.7	51	24
8670-28-3AMEU	76	2800	11	14	19	23	80	12.7		
8670-13-3AMEU	76	1350	13	16	22	23	80	12.7		
8670-8-3AMEU	76	800	14	19	25	23	80	12.7		
8670-4-3AMEU	76	450	16	22	32	23	80	12.7		

(1) These are "valve in head" models – Fitted as standard with 13 mm capacity chuck (8660 series) and 19 mm capacity chuck (8670 series).

(2) Delivered as standard with 8660 and 8670 series. – For other available strokes, see following page.

Dimensions (mm)

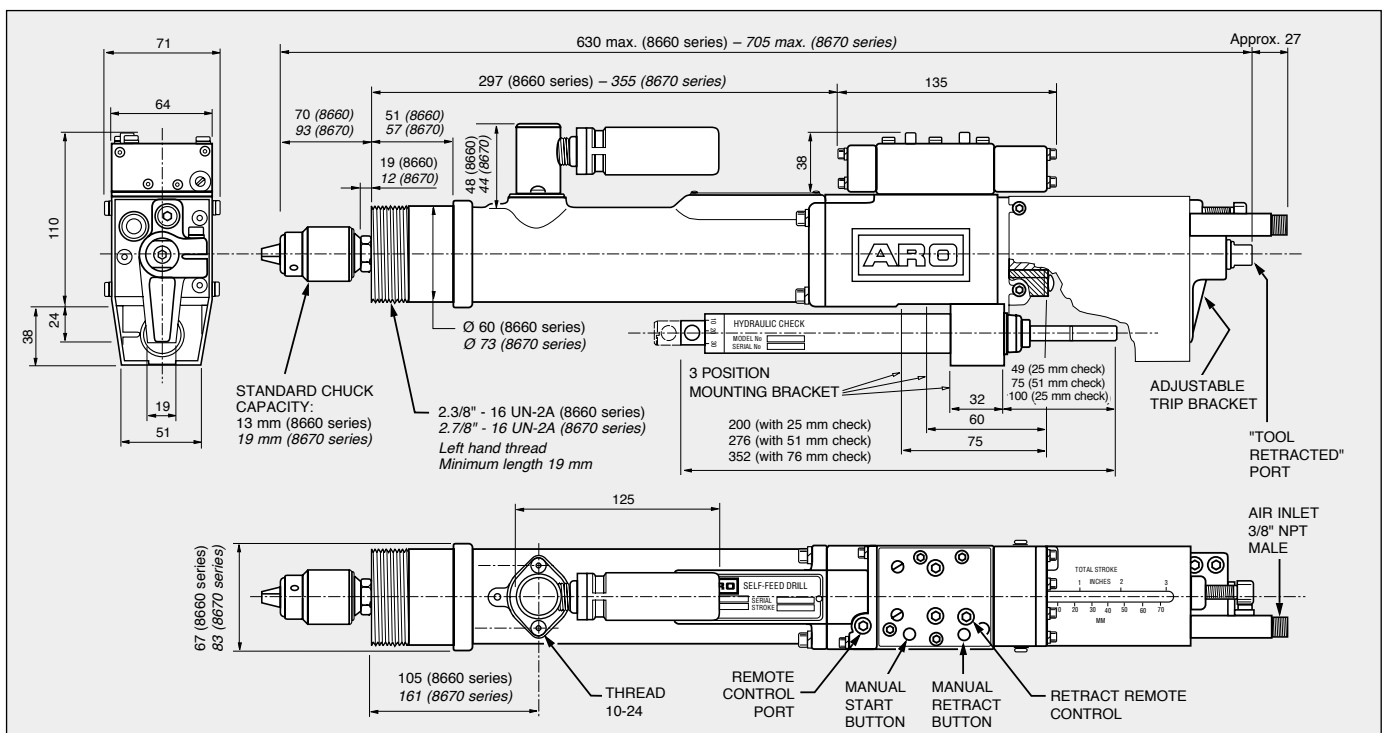

HI-THRUST 8660 & 8670 Pneumatic Units

Spindle Accessories

Hydraulic Check Units *(standard HI-THRUST series are supplied with a single check - 51 mm stroke - part no. 38922-1)*

Hydraulic check Assembly ⁽¹⁾	Stroke (mm)	Check Only			Mounting Bracket only	Check Diameter (mm)	Overall Length (mm)		
		25 mm Stroke	51 mm Stroke	76 mm Stroke			25 mm Stroke	51 mm Stroke	76 mm Stroke
SINGLE HYDRAULIC CHECK UNITS									
-	-	38922	38922-1 ⁽²⁾	38922-2	44910	24	200	276	352
TWIN HYDRAULIC CHECK UNITS									
46133-11	25	38922	-	-	46130	24	200	-	-
46133-12	25 and 51	38922	38922-1	-	46130	24	200	276	-
46133-13	25 and 76	38922	-	38922-2	46130	24	200	-	352
46133-22	51	-	38922-1	-	46130	24	-	276	-
46133-23	51 and 76	-	38922-1	38922-2	46130	24	-	276	352
46133-33	76	-	-	38922-2	46130	24	-	-	352

(1) Hydraulic check assemblies include twin checks and mounting bracket

(2) Delivered as standard with 8660 and 8670 series.

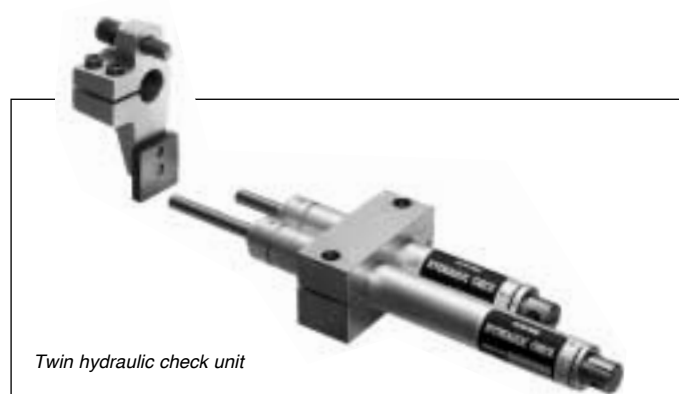
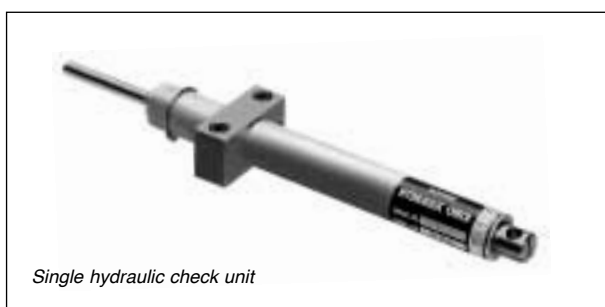

Drill Chuck

Compatible Units	Drill Chuck Part No.*	Size Range (mm)	Thread Size	Body Length min. / max. (mm)	Cutting Tool Penetration (mm)	Outside Diameter (mm)	Chuck Key No.
Hi-Thrust 8660	33907	1.6 - 9.5	1/2 - 20 R.H.	49 / 61	20.6	36	30510-K
	30018	2 - 13	1/2 - 20 R.H.	61.5 / 78.5	29	46	30016-K
Hi-Thrust 8670	45176	0 - 9.5	5/8-16 R.H.	59 / 78	24	46	30016-K
	45177	4.8 - 19	5/8-16 R.H.	81 / 104.5	39	65	45177-K

* Includes chuck key.



Taper Shank Adapter

Compatible Units	Morse Taper No.	Part No.	Female Thread Size	Length (mm)	Outside Diameter (mm)
Hi Thrust 8660	1	35211	1/2"	89	25.4
	2	31394	1/2"	101.5	25.4
Hi Thrust 8670	1	46090	5/8"	101.5	26.7
	2	46091	5/8"	114	29.7



HI-THRUST 8660 & 8670 Pneumatic Units

Spindle Accessories and Mounting Accessories

Collet Attachment

Collet No.	Size Range (mm) Min. / Max.	Insert	Collet No.	Size Range (mm) Min. / Max.	Insert	Collet No.	Size Range (mm) Min. / Max.	Insert
For HI-THRUST 8660 series only								
41758-1	0.4 / 1.2	31812-1	41758-4	2.4 / 3.2	31812-4	41758-7	4.8 / 5.5	31812-7
41758-2	1.2 / 2.0	31812-2	41758-5	3.2 / 4.0	31812-5	41758-8	5.5 / 6.4	31812-8
41758-3	2.0 / 2.4	31812-3	41758-6	4.0 / 4.8	31812-6			
SPECIFICATIONS: Length 65.1 mm – Outside diameter 19 mm – Female Thread 1/2-20 – Tool penetration 33.3 mm								
35069-1	5.5 / 6.4	35263-1	35069-5	8.7 / 9.5	35263-5	35069-9	11.9 / 12.7	35263-9
35069-2	6.4 / 7.1	35263-2	35069-6	9.5 / 10.3	35263-6	35069-10	12.7 / 13.5	35263-10
35069-3	7.1 / 7.9	35263-3	35069-7	10.3 / 11.1	35263-7	35069-11	13.5 / 14.3	35263-11
35069-4	7.9 / 8.7	35263-4	35069-8	11.1 / 11.9	35263-8			
SPECIFICATIONS: Length 82.5 mm – Outside diameter 44.5 mm – Female Thread 1/2-20 – Tool penetration 44.5 mm								
For HI-THRUST 8670 series only								
46093-1	5.5 / 6.4	35264-1	46093-7	10.3 / 11.1	35264-7	46093-13	15.1 / 15.9	35264-13
46093-2	6.4 / 7.1	35264-2	46093-8	11.1 / 11.9	35264-8	46093-14	15.9 / 16.6	35264-14
46093-3	7.1 / 7.9	35264-3	46093-9	11.9 / 12.7	35264-9	46093-15	16.6 / 17.4	35264-15
46093-4	7.9 / 8.7	35264-4	46093-10	12.7 / 13.5	35264-10	46093-16	17.4 / 18.2	35264-16
46093-5	8.7 / 9.5	35264-5	46093-11	13.5 / 14.3	35264-11	46093-17	18.2 / 19.0	35264-17
46093-6	9.5 / 10.3	35264-6	46093-12	14.3 / 15.1	35264-12			
SPECIFICATIONS: Length 76.2 mm – Outside diameter 41.3 mm – Female Thread 5/8-16 – Tool penetration 47.5 mm								

Foot Bracket

Compatible Unit	Foot Bracket Assembly	Lock Nut Only
Hi Thrust 8660	44970	44961
Hi Thrust 8670	45185	45179

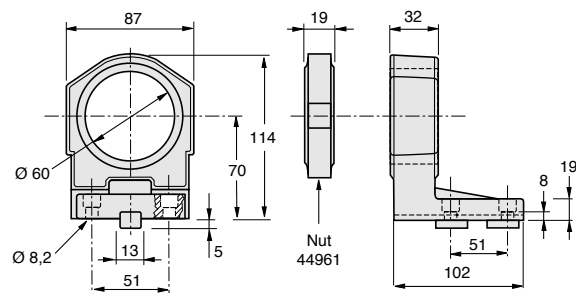

Part no. 44970 (for HI-THRUST 8660 series only)

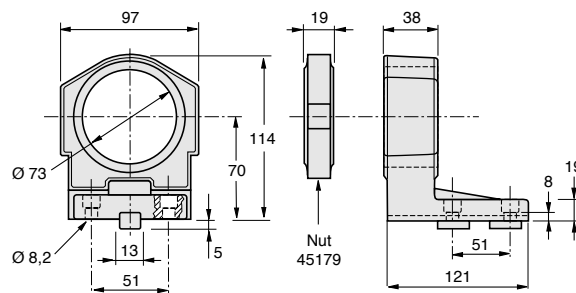

Part no. 45185 (for HI-THRUST 8670 series only)

HI-THRUST 8660 & 8670 Pneumatic Units

Mounting Accessories (cont)

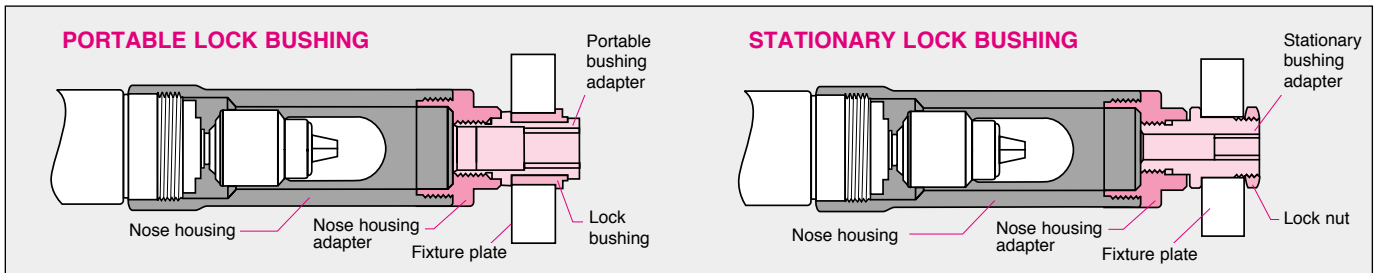

Nose Housings

Compatible Drill Models	Nose Housing Part No.	Thread Sizes		Length (mm) C	Diameter (mm)			Dim. (mm)	
		A To Tool	B To Bush Adapter		OD1	OD2	ID	E	F
Hi-Thrust 8860	44971-2	2.3/8"- 16 UN-2B L.H.	2.3/8"- 16 UN-2B L.H.	216	56	56	51	22	97
Hi-Thrust 8870	45188	2.7/8"- 16 UN-2B L.H.	2.3/8"- 16 UN-2B L.H.	249	92	92	74	25	155

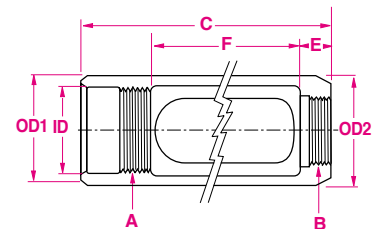

Nose Housing Adapters

Part No.	Thread Size		Dimensions (mm)	C	D	E	F
	A to Nose Housing	B to Drill Bushing Adapter					
33812	2.3/8"- 16 UN-2A L.H.	3/4"- 16 UNF-2B L.H.	44	22.2	16	47	
33751	2.3/8"- 16 UN-2A L.H.	1"- 14 UNF-2B L.H.	44	22.2	16	47	
33764	2.3/8"- 16 UN-2A L.H.	1.1/4"- 12 UNF-2B L.H.	44	22.2	16	47	
34075	2.3/8"- 16 UN-2A L.H.	1.1/2"- 12 UNF-2B L.H.	51	22.2	16	47	

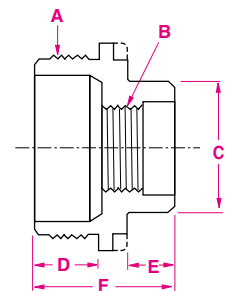

Portable Drill Bushing Adapters

Drill Bushing Adapter Part No.	Bore Dia. min. / max. (mm)	Interior Bush Dia. (mm) +0.03 -0.00	Lock Bushing* Part No.	Thread Size to Nose Housing A	Dimensions (mm)			Lock Bushing Dia. "D" (mm) +0.03 -0.03
					B	C		
35214	0.35 / 2.5	5.17	35215	3/4"	55.1	19.0	17.4	
35216	2.5 / 3.5	6.36	35217	16 UNF-2A L.H.	55.1	19.0	19.0	
35218	3.2 / 4.9	7.95	35219	16 UNF-2A L.H.	55.1	19.0	20.6	
35220	4.8 / 8.0	12.7	35221	1"-14 UNF-2A L.H.	55.9	19.0	25.4	
35222	8.0 / 13.5	19.0	35223	1.1/4"-12 UNF-2A L.H.	55.9	25.4	34.9	
35224	12.7 / 19.4	25.4	35225	1.1/2"-12 UNF-2A L.H.	67.3	28.6	44.4	

* Note: Portable drill bushing and lock bushing must be ordered separately.

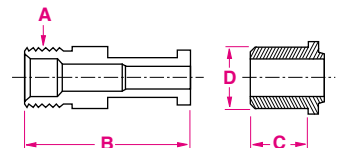

Stationary Drill Bushing Adapters

Drill Bushing Adapter Part No.	Bore Dia. min. / max. (mm)	Interior Bush Dia. (mm) +0.01 -0.00	Lock Nut* Part No.	Thread Size to Nose Housing A	Thread Size to Lock Nut B	Dimensions (mm)		
						C	D	E
36646	0.35 / 2.5	5.17		3/4"	1.1/4"	20.6	31.7	51
36647	2.5 / 3.5	6.36	38850	16 UNF-2A L.H.	12 UNF-2A	20.6	31.7	51
36648	3.2 / 4.9	7.95	38850	1"- 14 UNF-2A L.H.	1.1/4"-12 UNF-2A	27.0	31.7	56
36649	4.8 / 8.0	12.7	38850	1.1/4"- 12 UNF-2A L.H.	1.1/4"-12 UNF-2A	33.3	31.7	56
36650	4.8 / 8.0	12.7	46089	1.1/2"- 12 UNF-2A L.H.	1.5/8"-12 UNF-2A	39.9	38	56

* Note: Stationary drill bushing and lock nut must be ordered separately.

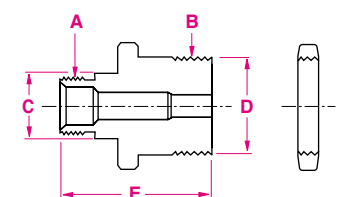

FE054C & FE074A Electro-Pneumatic Units

Specifications

- Electric powered, dual voltage AC.
- FE054C series; Motors B or C 0.37 kW
FE074A series; Motor 0.56 kW.
- Low cost pulley sets for speed interchange.
- Air thrust from 68 kg (at 2.8 bar) to 150 kg (at 6.2 bar).
- Air consumption: 1 L/cycle.
- Sound level 60 dBA.
- Weight: 13 kg.



Model No. FE054C-24B-AEU

Model No.	Max. Stroke (mm)	Free Speed (rpm)	Nominal Drilling Capacity (mm)		
			Steel	Aluminium	Wood
FE054C SERIES - MOTOR "B"					
FE054C-77B-AEU	110	6400	1.2	2.4	4.2
FE054C-67B-AEU	110	5600	1.4	2.8	4.6
FE054C-59B-AEU	110	4900	1.6	3.2	4.9
FE054C-54B-AEU	110	4500	1.8	3.5	5.2
FE054C-48B-AEU	110	4000	2.0	3.9	5.5
FE054C-43B-AEU	110	3500	2.2	4.7	6.4
FE054C-38B-AEU	110	3100	2.4	5.1	6.8
FE054C-34B-AEU	110	2800	2.8	5.5	7.1
FE054C-30B-AEU	110	2500	3.2	6.1	7.9
FE054C-27B-AEU	110	2200	3.5	6.7	8.7
FE054C-24B-AEU	110	2000	3.9	7.1	9.3
FE054C-22B-AEU	110	1800	4.2	7.5	9.8
FE054C-19B-AEU	110	1600	4.7	7.9	10.3
FE054C-17B-AEU	110	1400	5.2	8.7	11.5
FE074A SERIES					
FE074A-20B-AEU	102	1600	7	11	15

Model No.	Max. Stroke (mm)	Free Speed (rpm)	Nominal Drilling Capacity (mm)		
			Steel	Aluminium	Wood
FE054C SERIES - MOTOR "C"					
FE054C-38C-AEU	110	3200	2.4	5.1	6.8
FE054C-34C-AEU	110	2800	2.8	5.5	7.1
FE054C-30C-AEU	110	2450	3.2	6.1	7.9
FE054C-27C-AEU	110	2250	3.5	6.7	8.7
FE054C-24C-AEU	110	2000	3.9	7.1	9.3
FE054C-22C-AEU	110	1750	4.2	7.5	9.8
FE054C-19C-AEU	110	1550	4.7	7.9	10.3
FE054C-17C-AEU	110	1400	5.2	8.7	11.5
FE054C-15C-AEU	110	1250	5.8	9.5	12.6
FE054C-14C-AEU	110	1100	6.4	10.0	13.4
FE054C-12C-AEU	110	1000	7.1	10.5	14.5
FE054C-11C-AEU	110	900	8.5	11.1	15.5
FE054C-10C-AEU	110	800	9.5	11.8	16.5
FE054C-8C-AEU	110	700	11.1	12.7	17.5
FE074A SERIES					
FE074A-7B-AEU	102	600	13	15	24

Input and Output Controls



Solenoid kit part no. 49787 for remote control port.



159764-004 connector and 59690-000 capillary tube.

Part no. 49787: Electric Interface 24V DC for remote control port, start cycle, or emergency retract.

Part no. 49785: Electric switch kit for "spindle is in extended position" or "spindle is back" output signal.

NOTE:

Std. with AIR outputs include: • Spindle is in extended position
• Spindle is back

Std. with AIR inputs include: • Start cycle
• Emergency retract

Connectors, part no. **59764-004** (pack of 10 pcs.) and tube, part no. **59690-000** (30 m length) are available at extra cost.

Inputs and outputs can be easily converted to 24V DC operation with low-cost, add-on elements.

FE054C & FE074A Electro-Pneumatic Units

Dimensions

Dimensions - FE054C Series (mm)

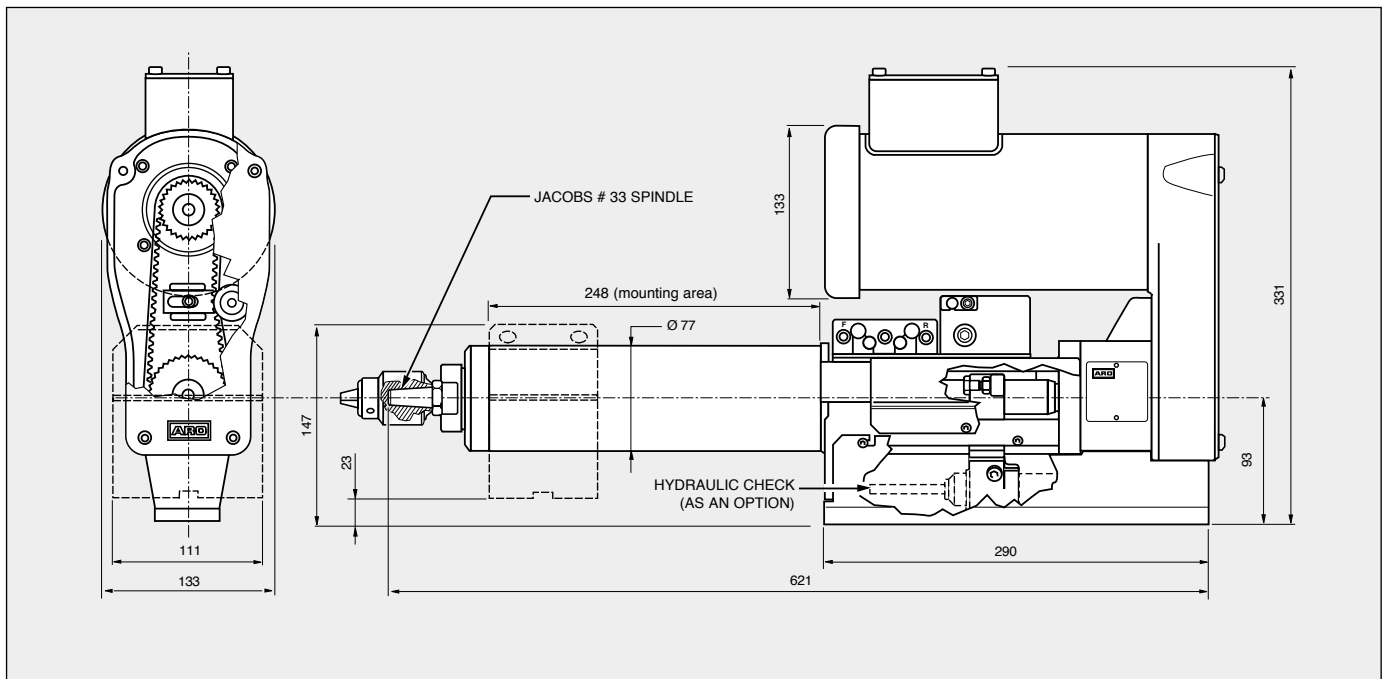

Dimensions - FE074A Series (mm)

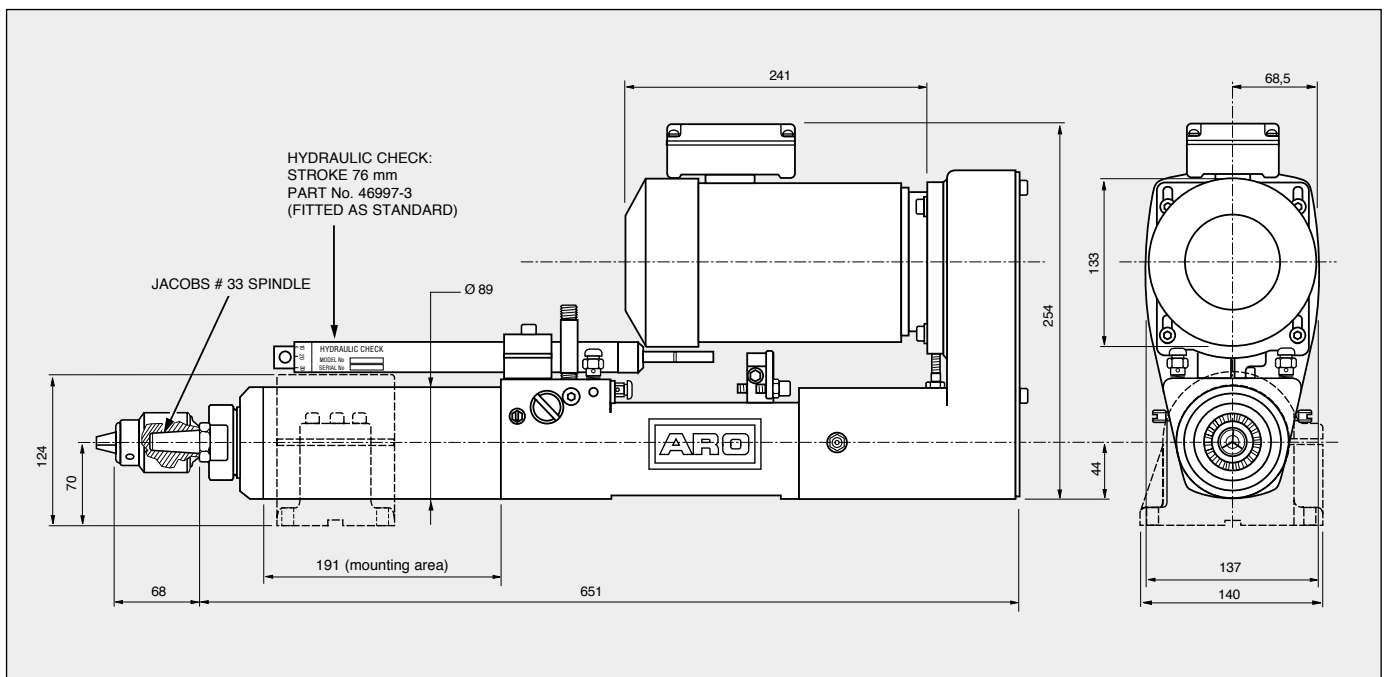

FE054C & FE074A Electro-Pneumatic Units

Spindle Accessories

Hydraulic Check Units

Hydraulic check Assembly ⁽¹⁾	Stroke (mm)	Check Only			Mounting Bracket only	Check Diameter (mm)	Overall Length (mm)		
		25 mm Stroke	51 mm Stroke	76 mm Stroke			25 mm Stroke	51 mm Stroke	76 mm Stroke
For FE054C series only									
—	—	38922	38922-1	38922-2	—	24	200	276	352
For FE074A series only (standard FE074A series are supplied with a single check - stroke 76 mm - part no. 46997-3)									
Single Hydraulic Check Unit									
46997-1	25	38922	—	—	46985	24	200	—	—
46997-2	51	—	38922-1	—	46985	24	—	276	—
46997-3 ⁽²⁾	76	—	—	38922-2	46985	24	—	—	352
Twin Hydraulic check unit									
46998-11	25	38922	—	—	46984	24	200	—	—
46998-12	25 and 51	38922	38922-1	—	46984	24	200	276	—
46998-13	25 and 76	38922	—	38922-2	46984	24	200	—	352
46998-22	51	—	38922-1	—	46984	24	—	276	—
46998-23	51 and 76	—	38922-1	38922-2	46984	24	—	276	352
46998-33	76	—	—	38922-2	46984	24	—	—	352

(1) Hydraulic check assemblies include check(s) and mounting bracket

(2) Delivered as standard with FE074A series.



Single hydraulic check unit for FE054C series

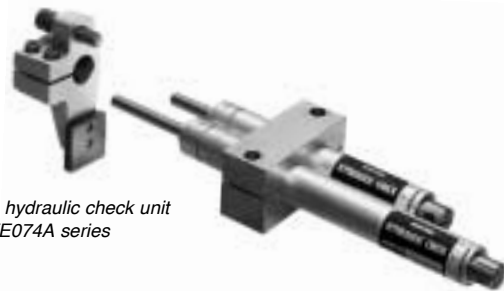

Twin hydraulic check unit for FE074A series

Drill Chuck

Part No.	Size Range (mm)	Mounting Style	Body Length min. / max. (mm)	Cutting Tool Penetration	Outside Dia. (mm)	Chuck Key No.
46977 ⁽¹⁾	2 - 12.7	# 33 Jacobs taper	64 / 82	27.5	45.5	30016-K
49905 ⁽²⁾	0 - 9.5	# 33 Jacobs taper	83 / 90.5	28.5	42.5	none

(1) Classic key chuck — (2) Keyless precision chuck



Taper Shank Adapter

Morse Taper No.	Part No.	Mounting Style	Length (mm)	Outside Diameter (mm)
1	46987	# 33 Jacobs taper	101.5	26.7
2	46986	# 33 Jacobs taper	114	29.7



Collet Attachment

Collet No.	Size Range (mm) Min. / Max.	Insert	Collet No.	Size Range (mm) Min. / Max.	Insert	Collet No.	Size Range (mm) Min. / Max.	Insert
48175-1	5.5 / 6.4	35264-1	48175-7	10.3 / 11.1	35264-7	48175-13	15.1 / 15.9	35264-13
48175-2	6.4 / 7.1	35264-2	48175-8	11.1 / 11.9	35264-8	48175-14	15.9 / 16.6	35264-14
48175-3	7.1 / 7.9	35264-3	48175-9	11.9 / 12.7	35264-9	48175-15	16.6 / 17.4	35264-15
48175-4	7.9 / 8.7	35264-4	48175-10	12.7 / 13.5	35264-10	48175-16	17.4 / 18.2	35264-16
48175-5	8.7 / 9.5	35264-5	48175-11	13.5 / 14.3	35264-11	48175-17	18.2 / 19.0	35264-17
48175-6	9.5 / 10.3	35264-6	48175-12	14.3 / 15.1	35264-12			

SPECIFICATIONS: Length 84 mm — Outside diameter 44 mm — # 33 Jacobs taper — Tool penetration 42.5 mm

FE054C & FE074A Electro-Pneumatic Units

Spindle Accessories (cont) and Mounting Accessories

Tapping Head Attachment

Tapping Attachment Part No.	Rubber Flex Insert Part No.	Tapping Capacity	Length (mm)	Outside diameter (mm)
49764*	21600 21700	M1.6 - M4 M5 - M6	114.3	53

* Includes two jacob's collets part Nos. 21600 and 21700



Twin Head Drill Attachment

Complete Head Assembly	Head only	Adapter only	Application	Adj. Spindle Centre distance Min. (mm)	Max. (mm)
47276	47768	47876	Drilling	19	95
47908	47768	47907	Tapping	19	95



Twin Head Collets

Bore Dia. (mm)	Part No.	Bore Dia. (mm)	Part No.	Bore Dia. (mm)	Part No.	Bore Dia. (mm)	Part No.	Bore Dia. (mm)	Part No.	Bore Dia. (mm)	Part No.	Bore Dia. (mm)	Part No.
2.0	46033-1	3.1	46033-12	4.2	46033-23	5.3	46033-34	6.4	46033-45	7.5	46033-56	8.6	46033-67
2.1	46033-2	3.2	46033-13	4.3	46033-24	5.4	46033-35	6.5	46033-46	7.6	46033-57	8.7	46033-68
2.2	46033-3	3.3	46033-14	4.4	46033-25	5.5	46033-36	6.6	46033-47	7.7	46033-58	8.8	46033-69
2.3	46033-4	3.4	46033-15	4.5	46033-26	5.6	46033-37	6.7	46033-48	7.8	46033-59	8.9	46033-70
2.4	46033-5	3.5	46033-16	4.6	46033-27	5.7	46033-38	6.8	46033-49	7.9	46033-60	9.0	46033-71
2.5	46033-6	3.6	46033-17	4.7	46033-28	5.8	46033-39	6.9	46033-50	8.0	46033-61	9.1	46033-72
2.6	46033-7	3.7	46033-18	4.8	46033-29	5.9	46033-40	7.0	46033-51	8.1	46033-62	9.2	46033-73
2.7	46033-8	3.8	46033-19	4.9	46033-30	6.0	46033-41	7.1	46033-52	8.2	46033-63	9.3	46033-74
2.8	46033-9	3.9	46033-20	5.0	46033-31	6.1	46033-42	7.2	46033-53	8.3	46033-64	9.4	46033-75
2.9	46033-10	4.0	46033-21	5.1	46033-32	6.2	46033-43	7.3	46033-54	8.4	46033-65	9.5	46033-76
3.0	46033-11	4.1	46033-22	5.2	46033-33	6.3	46033-44	7.4	46033-55	8.5	46033-66		

Mounting Clamp Assemblies:

Part no. 49690 (for FE054C series only)

Uses keys for alignment. Includes 3/8" x 1/2" keys.

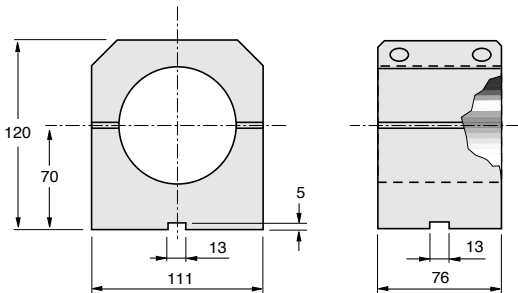

Part no. 46982 (for FE074A series only)

Uses keys for alignment. Includes 3/8" x 1/2" keys.

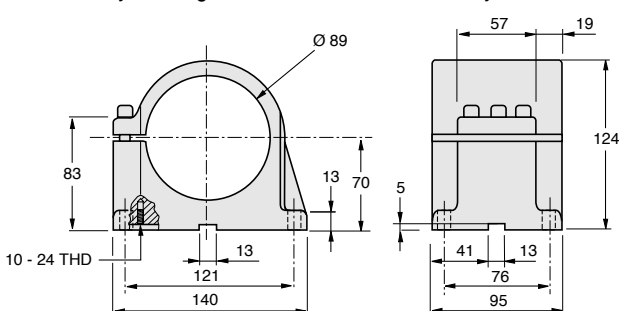

Riser: Part no. 46771 (for FE054C series only)

Provides necessary elevation for installations where the feed drill must clear the mounting plane. Bolts under 49690 clamp, and bolts down to mount surface.

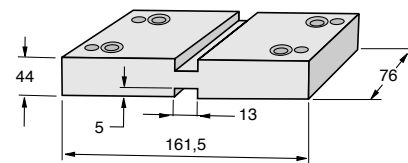

Tool mount assembly: Part no. 04333860

(for both FE054C and FE074A series). Used for mounting the FE series with the ARO Tubular Mounting System described page 24.

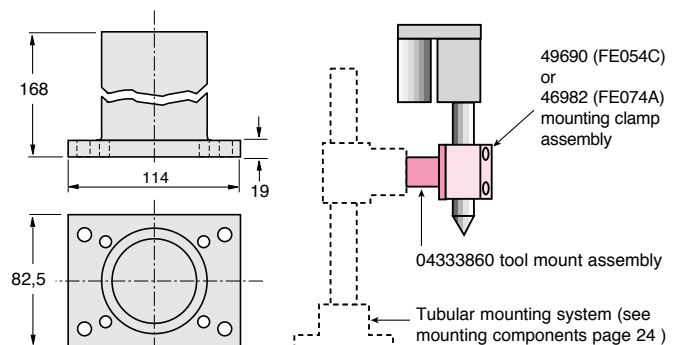

Manufacturing material	Cutting lubricant	Cutting speed "S" (m/min)	Feed Rate "F" Number "N" (rpm)	Bore diameter "D" (mm)								
				1 *	2	5	8	12	16	25	40	63
				Feed rate "F" (mm/turns) and average no. of turns per minute "N"								
Titanium and alloy titanium	Cutting oil	3 - 6	F	Hand	0.03	0.08	0.12	0.16	0.2	0.25	0.32	0.36
			N	1430	720	285	180	120	90	57	36	23
Soft plastic materials (PVC, polystyrol, plexiglass)	Water Compressed air	20 - 50	F	Hand	0.04	0.1	0.15	0.2	0.25	0.32	0.4	0.45
			N	11100	5600	2200	1400	930	700	450	280	180
Hard plastic materials (e.g. bakelite)	Compressed air	10 - 20	F	Hand	0.03	0.08	0.12	0.16	0.2	0.25	0.32	0.36
			N	4800	2400	960	600	400	300	190	120	75
Plastic material + organic material filling (insulating material, hard wood ...)	Compressed air	15 - 25	F	Hand	0.04	0.1	0.15	0.2	0.25	0.32	0.4	0.45
			N	6400	3200	1300	800	530	400	250	160	100
Plastic material + non-organic material filling (pulverised stone, glass fiber)	Compressed air	10 - 20	F	Hand	0.04	0.1	0.15	0.2	0.25	0.32	0.4	0.45
			N	4800	2400	960	600	400	300	190	120	75

* For bore diameters of less than 1 mm, reduce the cutting speed.

The above guidelines are only approximate values, the drilling depth and the nature of the material to be drilled must be taken into account to determine whether an increase or decrease in cutting speed is required.

The guidelines under "S" and "F" are only suitable for drilling when the depth does not exceed 5 times the bore diameter. When drilling between 5 to 8 times the bore diameter, reduce the "S" and "F" values by 20% and if drilling exceeds 8 times the bore diameter, reduce the values by 25-30%.

When drilling depths greater than 5 times the diameter, it is recommended, in general, to stop the operation from time to time in order to remove chip build up.

Cutting Speeds and Feed Rates for Reamers

The cutting speeds and feed rates for drill bits are equally suitable for reamers. For the latter, the cutting speeds indicated are to be considered as maximum values and the feed rates as minimum values.

Cutting Speeds and Feed Rates for Check-pin Drill Bits

S = 65 % - 75 % of the values indicated for the drill bits, taking the bore diameter as an average base.

F = 75 % of the values indicated for the drill bits, using the smallest bore diameter as a base.

Instructions for One-lipped Carbide Drill Bits

Manufacturing material	Cutting speed "S" (m/min)	Feed rate "F" (mm/min)
Steel, depending on durability	50 - 150	30 - 180
Grey cast iron, depending on durability and quality	40 - 120	60 - 200
Copper, brass (for long splinters), aluminium	100 - 250	100 - 300

Fundamental Guidelines for using One-lipped Drill Bits

Low feed rates - High cutting speeds.

The most favourable conditions in each particular case can only be determined by tests in which the grade of the tungsten carbide used is of essential importance.



KAVON CZ s.r.o.

Sídlo společnosti:

Smilova 777
530 02 Pardubice

Provozovna:

Medlešice 139
538 31 Chrudim

info@kavon.cz
www.kavon.cz

Pobočky:

Praha

Geologická 2,
152 00 Praha 5
tel./fax.: 222 741 604
mobil: 603 848 716
email: skridlovsky@kavon.cz

Mladá Boleslav

Staré Město 85
293 01 Mladá Boleslav
tel.: 326 322 158
mobil: 736 753 975
email: kavon.mb@kavon.cz

Brno

Hviezdoslavova 55
627 00 Brno-Slatina
tel.: 548 213 068
mobil: 603 893 537
email: simko@kavon.cz